

Architectures and Bandwidth Allocation Schemes for Hybrid Wireless-Optical Networks

Antonios G. Sarigiannidis, *Student Member, IEEE*, Maria Iloridou, Petros Nicopolitidis, *Senior Member, IEEE*, Georgios Papadimitriou, *Senior Member, IEEE*, Fotini-Niovi Pavlidou, *Senior Member, IEEE*, Panagiotis G. Sarigiannidis, *Member, IEEE*, Malamati D. Louta, *Senior Member, IEEE*, and Vasileios Vitsas

Abstract—The combination of the most prestigious optical and wireless technologies for implementing a modern broadband integrated access network has been progressively gaining ground. By extending the network coverage in a cost-efficient way, hybrid wireless-optical networks are able to enclose a larger number of potential subscribers than standalone access architectures. Hence, they are capable of increasing revenue levels and facilitating commercial penetration to the telecom market. At the same time, hybrid wireless-optical networks pose an ambitious, alternative, and efficient solution to coping with new bandwidth-hungry user applications. Hybrid wireless-optical networks incorporate sophisticated modules, fabrics, and network entities to effectively provide adequate quality of service (QoS) provisioning. This survey endeavors to classify the main features of wireless-optical integration. We provide a comprehensive compilation of the latest architectures, integrated technologies, QoS features, and dynamic bandwidth allocation (DBA) schemes. In addition, new trends towards wireless-optical convergence are presented. Moreover, as the up-to-date hybrid network standards remain under development, since there is not yet an integrated standard for approving hybrid network access platforms, we accompany this survey with detailed challenges indicating potential avenues of future research.

Index Terms—Access networks, DBA, FiWi, hybrid wireless-optical, integrated architectures, LTE, passive optical networks, Wi-Fi, WiMAX.

I. INTRODUCTION

AS THE ACCESS networking remains the most arduous bottleneck in modern telecommunication networks, the need for covering more users in larger regions in the most efficient way has emerged as a strong challenge. Modern communication systems will be increasingly complex involving

Manuscript received November 22, 2013; revised June 22, 2014; accepted August 6, 2014. Date of publication September 15, 2014; date of current version March 13, 2015. This research has been co-financed by the European Union (European Social Fund—ESF) and Greek national funds through the Operational Program “Education and Lifelong Learning” of the National Strategic Reference Framework (NSRF)—Research Funding Program: ARCHIMEDES III. Investing in knowledge society through the European Social Fund.

A. G. Sarigiannidis, P. Nicopolitidis, and G. Papadimitriou are with the Department of Informatics, Aristotle University of Thessaloniki, Thessaloniki 54124, Greece (e-mail: asarigia@csd.auth.gr; petros@csd.auth.gr; gp@csd.auth.gr).

M. Iloridou and F.-N. Pavlidou are with the Department of Electrical and Computer Engineering, Aristotle University of Thessaloniki, Thessaloniki 54124, Greece (e-mail: iloridou@auth.gr; niovi@auth.gr).

P. G. Sarigiannidis and M. D. Louta are with the Department of Informatics and Telecommunications Engineering, University of Western Macedonia, Kozani 50100, Greece (e-mail: psarigiannidis@uowm.gr; louta@uowm.gr).

V. Vitsas is with the Department of Informatics, Alexander TEI of Thessaloniki, Thessaloniki 57400, Greece (e-mail: vitsas@it.teithe.gr).

Digital Object Identifier 10.1109/COMST.2014.2356640

thousands of heterogeneous nodes with diverse features and capabilities and various networking technologies with different characteristics and capabilities. Their aim is to provide users with ubiquitous access to information and advanced services at a high quality level in a cost efficient manner, any time, any place. Even though during the last decade the capacity of core networks has experienced significant growth to meet the increasing bandwidth requirements, access networks connecting users to core networks, constitute one of the most tricky puzzle, known also as the “last mile” [1].

This puzzle is structured in two dimensions. In the aspect of bandwidth provisioning, access networks have to scale up in bandwidth capacity to enable high-speed data transmissions to satisfy user requirements and constraints with respect to bandwidth-demanding applications, such as video on demand (VoD), high-definition television (HDTV), online gaming and high quality voice over IP (VoIP) [2]. On the other hand, network connectivity has to be independent of the users’ location. Since the current copper-based access technologies (e.g., xDSL technology) are reaching their limits to keep up with bandwidth requests and emerging demanding applications, a viable solution to the aforementioned limitation can be found based on the two most promising candidates for covering the gap in the access domain [3]: a) broadband wireless solutions that are able to support multiple, and even mobile, end users in large regions, such as worldwide interoperability for microwave access (WiMAX)—IEEE 802.16 [4]–[9], third generation partnership project (3GPP) long term evolution (LTE) [10]–[14], and wireless fidelity (Wi-Fi), e.g., legacy IEEE 802.11, in a mesh environment [15]–[17], and b) the optical technology that brings huge bandwidth, however in specific, fixed, and predefined optical paths, such as the passive optical network (PON) technology [18].

Although PONs support high-bandwidth and reliable service provision, they require mass deployment of fiber optic infrastructure to connect multiple subscribers at homes or business premises (fiber to the home—FTTH). Furthermore, long-reach PONs emerge as a possible solution to provide connectivity to subscribers that reside 60 Km or more from the central office (CO), nevertheless they demand complex deployment infrastructure, signal regenerators, and demanding centralized control. Thus, introduction of PON technology to the last mile increases the necessitated investments and the respective capital expenditure [19]. On the other hand, wireless access technologies require less infrastructure deployment, while they are able to provide flexible and ubiquitous connectivity. However, due

to their limited capacity, autonomous wireless access solution is “problematic” with respect to bandwidth demanding applications support. The leverage of the complementary advantages of both technologies could provide a viable access solution, deploying a hybrid wireless-optical access network, known as fiber-wireless (FiWi) networks, where the optical infrastructure could be terminated at the curb (fiber to the curb—FTTC) or at the building (fiber to the building—FTTB) and wireless access points could expand the broadband access connectivity to the end users. To fully exploit the benefit, stemming from the convergence of PON and wireless technology, the design of modern architectures should incorporate integrated bandwidth allocation and transmission scheduling schemes.

In this work, we endeavor to provide an insightful survey on the most important and promising hybrid wireless-optical access solutions. Hybrid architectures, innovative converged implementation solutions, connection options and fabrics, bandwidth allocation schemes, and resource allocation algorithms are features that this survey tries to comprehensively cover. Also, special focus is given to quality of service (QoS) provisioning strategies as well as to the proposed common QoS-aware policies. Moreover, we intend to pinpoint new trends and unresolved pitfalls regarding the wireless-optical integration accomplishment, open challenges in the pertinent area, and design, operation, and optimization opportunities. Lastly, protocols, algorithms, and schemes providing integrated bandwidth allocation solutions are identified, discussed, and classified.

The remainder of the article is structured as follows. Section II provides the motivation and contribution supported by this article. Section III outlines the key technologies enabled in the wireless-optical integration. Section IV classifies the FiWi networks, while Section V compiles the existing integrated architectures. Techniques of combining the enabled technologies towards a converged wireless-optical network are analyzed in Section VI. The dynamic bandwidth allocation (DBA) taxonomy is introduced in detail in Section VII. Section VIII outlines new trends in integrating wireless and optical networks, while Section IX enumerates research challenges. Finally, Section X concludes this survey.

II. MOTIVATION AND CONTRIBUTIONS

The integration of optical and wireless networks as a hybrid FiWi access network promises a powerful network, as it can take advantage of the huge bandwidth potential of the optical fiber and the ubiquity and mobility of wireless access networks. Essentially, optical and wireless technologies could complement each other building a single network able to support emerging unforeseen applications and services that require high bandwidth and in some cases mobility.

Instead of focusing on enabling technologies and architectures [20], [21], specific infrastructures, e.g., smart power FiWi networks [22] or wireless optical broadband access networks (WOBANs) [23], research challenges [24], or DBA algorithms [25], in this work we thoroughly present a) background knowledge of the fiber and wireless part of the FiWi network, b) broad understanding of the entire network system, c) contemporary hybrid architectures and infrastructure solutions, d) novel DBA

algorithms, techniques, and schemes, e) new trends on integrating wireless an optical networks, and f) open research aspects and challenges. The contribution of this work lies in the comprehensive presentation of the most important features a hybrid FiWi entails. Moreover, QoS-related blocks, frameworks, algorithms, and schemes are investigated and classified, giving emphasis on high quality data delivery in modern FiWi systems.

Initially, the properties of the FiWi systems are identified and accordingly compiled. The taxonomy of the various integration options regarding the connection points of the optical and wireless networks follows. Then, we discuss and compare the converged technologies presented in the literature composing an integrated wireless-optical network. The classification of DBA schemes, designed and implemented up-to-now comes next, providing insights into DBA inner components.

Informative remarks are presented after each classification shedding light to subtle differences and critical issues. Afterwards, new trends, architectures, and premature technologies are identified. Finally, we provide focused research challenges, pinpointing the so far shortcomings, potential solutions and open research fields.

III. PRELIMINARIES

This Section presents an overview of the enabled technologies and architectures in hybrid wireless-optical networks, including both optical and wireless frameworks.

A. Passive Optical Network

PON technology is one of the most promising candidates to govern broadband access, due to its essentially unlimited and cost-effective bandwidth potential. FTTx (Fiber To The x) technologies are realized by PONs, creating optical lightpaths without incorporating optical-to-electrical conversion. Typically, the PON has a physical tree topology with the CO located at the root and the subscribers connected to the leaf nodes of the tree. The main network entities of a PON are the optical network units (ONUs), providing to users connection to the network, and the optical line termination (OLT), providing to ONUs access to the backbone. A passive optical splitter/combiner connects the OLT and ONUs, receiving a single optical fiber from the OLT and distributing the incoming signal to multiple single optical fibers and vice versa. A shared network based on a PON has several advantages [26]:

- Lower capital expenditures, since no electronic components are included.
- Lower operational expenditures, due to lack of electrical maintenance and monitoring.
- High reliability due to absence of vulnerable electronic components.
- Transparency and common signal format due to seamless optical light-paths.
- Scalability. A PON infrastructure could be easily upgraded by adding extra wavelengths leaving the core deployment intact.

Fig. 1 illustrates a typical PON. The most common used topology is the tree, since it defines a straightforward way of

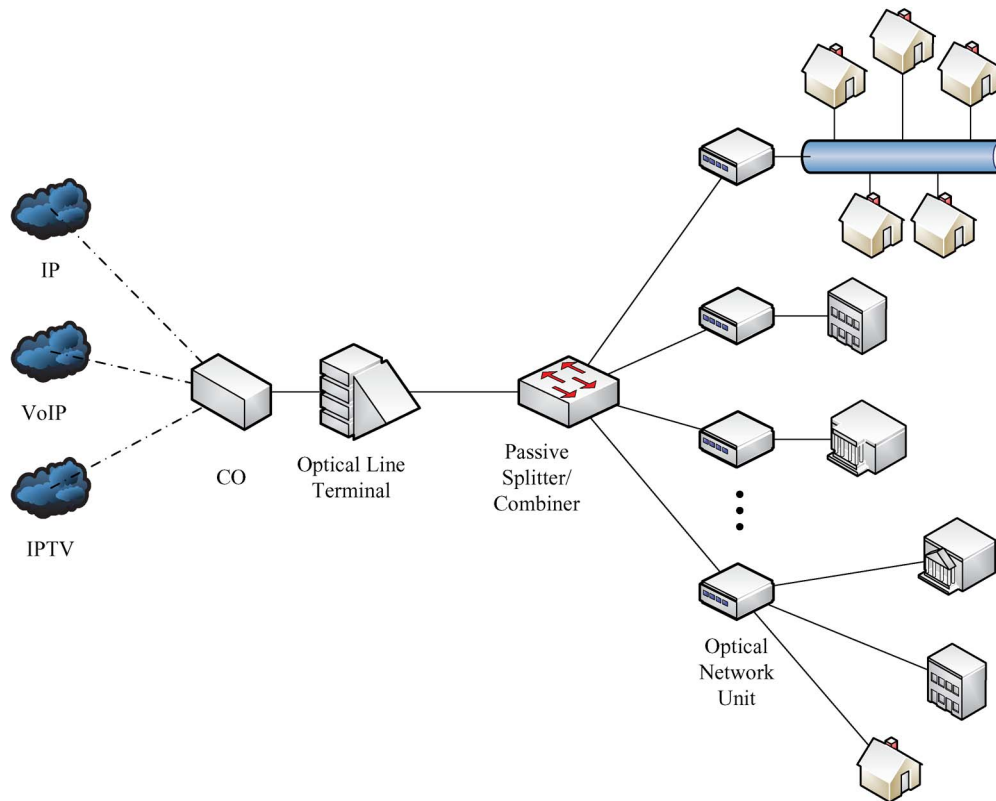

Fig. 1. A typical PON infrastructure.

broadcasting data streams from the OLT to the ONUs. Thus, the main challenge in bandwidth allocation lies in the uplink direction where the ONUs obey to a common (transmission) schedule constructed by the OLT. This schedule includes allocation opportunities for each ONU, allowing the sharing of the common optical fiber, i.e., the link connecting the OLT with the passive optical splitter/combiner, in a predefined access fashion. Collisions in the shared link are not allowed.

PONs can be divided into four main categories, namely Ethernet PONs (EPONs), Gigabit PONs (GPONs), wavelength division multiplexing (WDM) PONs, and orthogonal frequency division multiplexing (OFDM) PONs.

Recently, the term new generation PON (NG-PON) has emerged to cover the most contemporary standardized systems. According to [27], [28], NG-PON technology fall into two categories: a) evolutionary NG-PON technologies which are able to co-exist with legacy PONs, and b) revolutionary NG-PON technologies, such as optical code division multiplexing (OCDM) PONs which are expected to replace current state-of-the-art legacy PONs in the near future. Revolutionary PONs are today deemed as premature. On the other hand, evolutionary PONs became sophisticated enough to be capable of cooperating with wireless architectures in a common hybrid network. Thus, in this work, we mostly focus on the evolutionary PONs. Nonetheless, considerable research directions are given as new trends, later in the article, even they are in their infancy, to provide insights in this promising field.

EPON: The Ethernet in the first mile (EFM) established the formation of the P802.3ah task force finalizing the approval of the IEEE 802.3ah standard [29]. In the media access control

(MAC) layer the interconnection of the OLT with the ONUs takes place using Ethernet frames. In the downstream direction, Ethernet frames transmitted by OLT pass through a 1 : N passive splitter and reach each ONU. Hence, a point-to-multipoint (P2MP) architecture is implemented. In the upstream direction, due to directional properties of the passive combiner/splitter, Ethernet frames from any ONU will only reach the OLT, not other ONUs [30]. In that respect the upstream direction follows a point-to-point (P2P) architecture.

EPON systems utilize two wavelengths for delivering data to end users. The most popular solution to channel separation is to use a 1550 nm wavelength for downstream transmission and another 1310 nm wavelength for upstream transmission. Moreover, it is a common practice to utilize one or more (in-band) control channels to transfer control messages between the OLT and the ONUs.

There is a common clock governing all ONUs to provide a global time reference. The slotted technique is the most common method of providing a time division basis, where each ONU is attached to a specific time slot. Each ONU starts transmitting only upon the beginning of the time slot dedicated to this ONU. This type of allocation scheme is called *static* or *fixed*. It incorporates fixed time division multiple access (TDMA) bandwidth allocation [30]; however a TDMA scheme is not sufficient to meet the QoS requirements and the various service level agreements (SLAs). It is worth mentioning that the IEEE 802.3ah does not specify a complete bandwidth allocation policy.

Next generation Ethernet-based PON supports 10 Gb/s Ethernet lines and it is known as 10G EPON (GE-PON) [31].

Beyond the high-rate optical rate, the GE-PON framework inherits the majority of the EPON features considering the bandwidth allocation process.

Considering QoS provisioning, an IEEE 802.3ah ONU is allowed to maintain up to eight queues [29]. The EPON service classes are divided into three categories, namely expedited forwarding (EF), assured forwarding (AF), and best effort (BE). Services that include voice, or delay-sensitive applications, where the delay and the jitter are of paramount importance, belong to the EF category having the highest priority. Bandwidth guaranteed applications, such as video on demand, fall within the AF category. Lastly, BE class includes low-priority applications and services having no limitations in delay or throughput such as e-mail and web surfing.

Regarding bandwidth allocation provisioning, the EPON is responsible for providing end users with access to the backbone. Since the interface of the EPON with the backbone network is realized through the OLT, the direction from the OLT to the ONUs, and therefore to the end users, defines the downlink flow. Logically, the data delivery in the downlink direction is a straightforward task considering that the OLT is completely aware of the bandwidth needs of all users. Hence, it applies a data broadcast in the downlink direction, delivering data from the backbone to the end users. On the other hand, the uplink flow is formed as the traffic goes towards to the backbone network, i.e., from the ONUs to the OLT. Due to limited upstream bandwidth, an EPON system may not always be able to provide sufficient bandwidth to meet the bandwidth demand of all end users. A dynamic bandwidth allocation policy is required to grant bandwidth to each ONU based on the traffic dynamics of the ONUs.

To address this problem, various polling strategies have been proposed, however the (MPCP) mechanism [29] is the dominant standard-compliant polling scheme widely adopted by EPON and GE-PON systems. MPCP constitutes a coordination protocol for realizing a) dynamic bandwidth allocation, b) arbitrating, c) signaling, d) synchronization, and e) registration and discovery processes. It operates at the MAC sub-layer and incorporates two operation modes: the normal mode and the auto-discovery mode. In normal mode, MPCP involves two important control messages: the GATE message and the REPORT message. GATE message is used by the OLT to allocate a transmission window to an ONU. It is usually carried via a separate, dedicated (in-band) control channel from the OLT to the ONUs, giving permission to each ONU separately to begin transmission in a specific time window. REPORT messages inform the OLT about the ONUs' queue status, thus carry the ONU's bandwidth demands. REPORT messages are piggybacked into the real data and both are transmitted via the upstream data channel. Fig. 2 illustrates the function of the MPCP process in the OLT-ONUs interconnection.

To better exhibit the MPCP-based polling mechanism an illustrative example is given. Fig. 3 demonstrates the polling stages of an EPON with an OLT and three ONUs. Initially, a cycle is inaugurated by the OLT when it sends a GATE message to each ONU. Upon receiving the GATE message, each ONU is aware of the granted transmission time and the transmission duration as well. To this end, ONUs send their data streams to

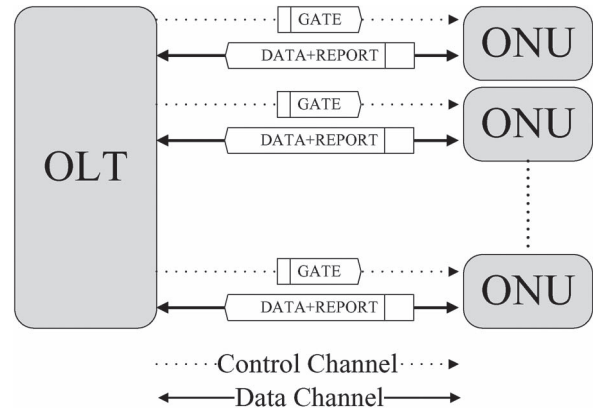

Fig. 2. The MPCP process.

the common uplink channel. A REPORT message, denoted as RTP in Fig. 3, is piggybacked into data stream to inform OLT about the ONUs' traffic requests. It is worth mentioning that this example describes a generic MPCP-based polling scheme; more paradigms may be found in the literature [31].

Beyond the bandwidth distribution operation, there is a dichotomy on the way of arbitrating the contending for access transmissions. First, the inter-ONU scheduling is responsible for arbitrating the transmission of different ONUs. Second, the intra-ONU scheduling is responsible for arbitrating the transmissions of different priority queues in each ONU [32]. Usually, the OLT incorporates both scheduling operations. Hence, it constitutes the core decision making component of the whole network. Nevertheless, in hybrid wireless-optical networks there is the need for distributed decision making. In this case, the OLT applies inter-ONU scheduling and each ONU performs intra-ONU scheduling. In this way, each ONU requests the OLT to allocate bandwidth for it based on its buffer occupancy status and then it will divide the allocated bandwidth among different classes of services based on the existing QoS requirements. Fig. 4 illustrates the inter-ONU scheduling while Fig. 5 demonstrates the intra-ONU scheduling.

GPON: The gigabit-capable PON (G-PON) is standardized by International Telecommunication Union-Telecommunication Standardization Sector (ITU-T) G.984 series [33]–[36]. The G-PON framework supports a two-wavelength scheme, implementing one channel for each direction [26]. GPON is deployed in a tree topology and hence the ONUs share the upstream channel between the splitter and the OLT. The communication between the OLT and ONUs is realized by fixed-time frames of 125 μ sec in both downstream and upstream directions. The broadcast frame defines common clock synchronization and broadcasts data and control information together in the same format. Each downstream frame consists of a physical control block (PCBd) followed by a payload block. PCBd includes an upstream bandwidth map (BWmap) which defines the transmission beginning time and the bandwidth allocated (transmission duration) of an ONU regarding its allocation in the upstream channel. Similar to EPON, static allocation in constructing the bandwidth allocation in the upstream direction is avoided due to low performance. ITU-T specifies two different DBA mechanisms: *status reporting* and *non-status reporting*. With status reporting, ONUs regularly report their buffer status to the

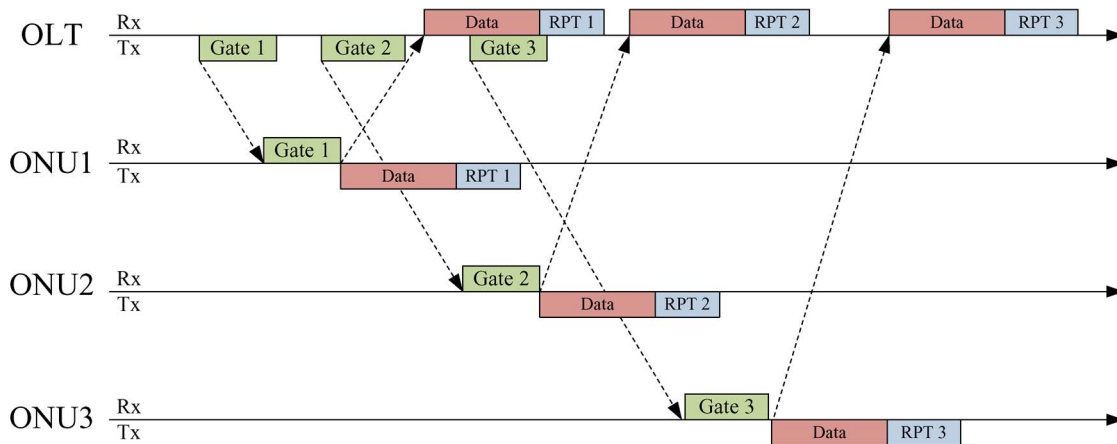

Fig. 3. A generic MPCP-based polling scheme for EPON systems.

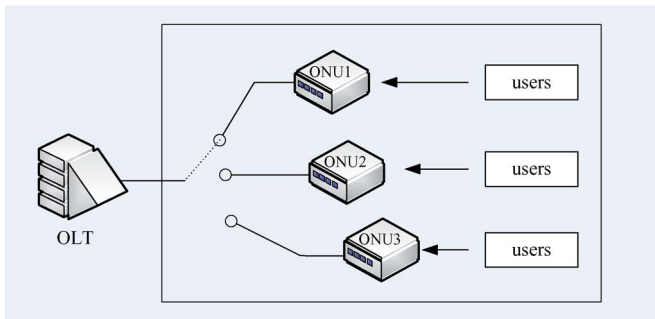

Fig. 4. The inter-ONU scheduling paradigm.

OLT and the OLT defines the BWmap accordingly. The non-status reporting strategy incorporates an estimation method, by which the OLT attempts to adapt its bandwidth allocation policy in accordance to the ongoing ONUs bandwidth needs.

Likewise EPON, the QoS provisioning in GPON is based on service classes, known as transmission containers (T-CONTs). A T-CONT is the unit of upstream bandwidth allocation by the OLT. The T-CONT arrangement is configurable by the OLT; however, popular schemes are a single T-CONT per ONU, or multiple T-CONTs, one per service class, per ONU. According to G.983.4 five T-CONTs are defined as follows:

- 1) T-CONT 1 class handles constant bit-rate (CBR) applications with strict demands for throughput, delay, and delay variation.
- 2) T-CONT 2 class focuses on variable bit-rate (VBR) traffic, suitable for video and voice applications which have predefined throughput requirements.
- 3) T-CONT 3 class offers a guaranteed minimum transmission rate.
- 4) T-CONT 4 class is intended for BE connections.
- 5) Lastly, T-CONT 5 class constitutes a combination of all the above, e.g., strict CBR applications and BE connections.

The ten-gigabit-capable passive optical network (XG-PON) system constitutes the next generation GPON standard. It is the newest member of the ITU-T family of passive optical network standards [37]–[40]. 10G EPON and XG-PON enable bit rates up to 10 Gb/s.

An instance of the bandwidth allocation process in (X)G-PON systems is drawn in Fig. 6. The term Alloc-ID is associated with the user traffic profiles. For example, ONU2 governs two traffic profiles, i.e., two T-CONTs. The subtle difference between (G)E-PON and (X)G-PON systems in terms of bandwidth allocation lies in the role of the downstream frame. (X)G-PON systems employ the BW-map (control) field to inform all ONUs (at the same downstream frame) about the granted uplink transmission opportunities. Hence, (X)G-PON systems apply a holistic coordination using a single downstream frame per cycle, whereas (G)E-PON systems utilizes a per-ONU individual GATE messages.

WDM-PON: The main property of the WDM-PONs is the usage of multiple wavelengths in a single fiber for both downlink and uplink direction. The WDM-PON architecture is enhanced with a passive wavelength router instead of the passive splitter to be able to support unrestricted wavelength forwarding, i.e., when it is deployed in a tree topology. As a result, each OLT-ONU pair has a dedicated and permanent wavelength assignment, and requires two transmitter/receiver pairs to form a point-to-point link [26]. A passive wavelength router located at the remote node is realized by arrayed waveguide grating (AWG) or a set of thin film filters (TFFs). Even though WDM-PONs offer tremendous bandwidth capabilities, they currently suffer from optical power budget issues, a fact that may delay the commercial approval of a WDM-PON standard. However, many works propose a WDM-PON framework in the optical domain of a potential hybrid wireless-optical network.

In terms of bandwidth allocation the WDM-PONs are more efficient, however a more sophisticated DBA scheme is required since the ONUs share both timeslots and wavelengths (channels). Ideally, a wavelength is devoted to each ONU solving the bandwidth allocation in the upstream direction adequately. Nevertheless, wavelength limitations, stemming from the high operational cost of multi-channel capable transceivers, lead to hybrid TDM-WDM way of applying resource allocation to the users. One the most widely used bandwidth allocation method is the extended MPCP, which is favored among multitude state-of-the-art schemes due to its guarantee backward compatibility with legacy TDM EPONs.

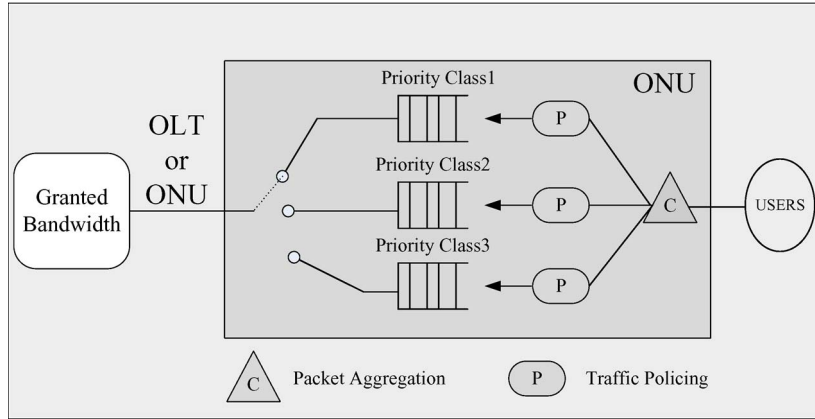

Fig. 5. The intra-ONU scheduling paradigm.

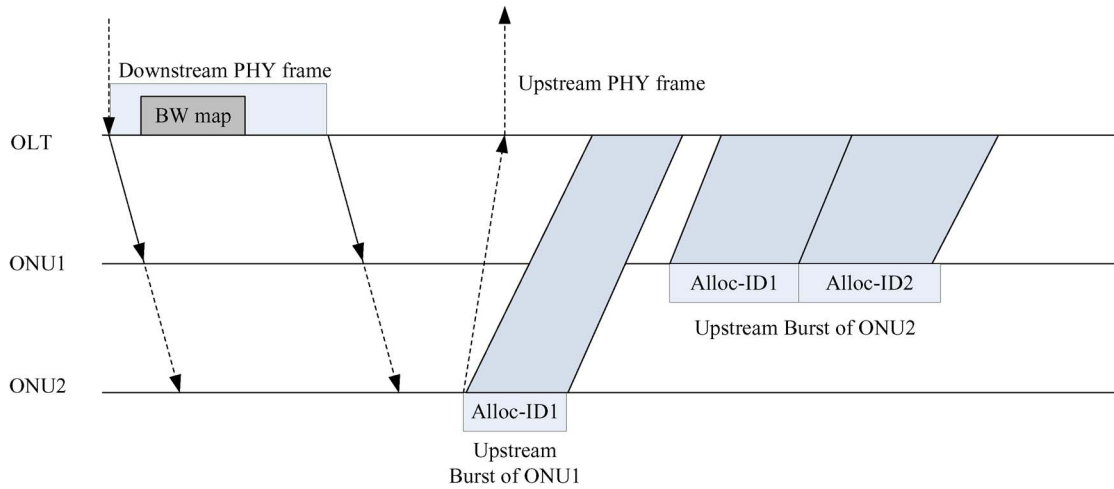

Fig. 6. Bandwidth allocation process in (X)G-PON systems.

Fig. 7 depicts the operation of the extended MPCP mechanism in a WDM-EPON with three channels in both upstream and downstream direction. It is clear that empowering the system with more channels leads to better network performance, i.e., the cycle duration is shortened since allocation in parallel is allowed by the WDM nature of the network.

OFDM-PON: An OFDM-PON has a similar architecture to conventional PON (e.g., TDM-PON) and uses two wavelengths, one for uplink and one for downlink data delivery. Its unique feature lies in the definition of sub-bands, where the entire bandwidth is divided to N separate and interference-free sub-channels [41]. Thus, groups of subcarriers can be dynamically assigned to different ONUs bidirectionally to address their temporal bandwidth requirements. This capability is demonstrated in Fig. 8. Three ONUs share different subcarriers. The OLT broadcasts a common downlink frame to all ONUs. Each ONU receives the whole frame, applies suitable filtering, and keeps the OFDMA regions of its interest.

Due to their flexibility in forming virtual transmission pipes of variable bandwidth at the physical (PHY) layer, OFDM-PONs are particularly attractive for backhauling high-capacity wireless networks [42]. The ACCORDANCE FP7 project focuses on developing hybrid solutions including OFDM-PONs as the core network part.

B. WiMAX Access Network

WiMAX constitutes one of the most promising broadband access technologies in the next generation networking environment, supporting high capacity, long-distance communication and user mobility. WiMAX is based on wireless metropolitan area networking (WMAN) standards developed by the IEEE 802.16 group [4]–[8]. It adopts orthogonal frequency division multiple access (OFDMA), enabling multiple users to utilize different bandwidth regions in the time and frequency domains. To this end, OFDMA combines time and frequency division multiple access, providing multiple timeslots at different frequencies to multiple users. Full duplex communication is achieved by dividing the entire MAC frame into two sub-frames, the downlink sub-frame carrying data from a base station (BS) towards subscriber stations (SSs) and the uplink sub-frame transmitting data from SSs towards the BS. Fig. 9 illustrates a WiMAX access network.

Frequency division duplexing (FDD) or time division duplexing (TDD) techniques may be applied for the transmission of the two sub-frames. The TDD is favored by the majority of services mainly due to its flexibility and simplicity. Fig. 10 shows a TDD instance frame. The WiMAX PHY frame duration is variable between 2–20 ms. The BS is responsible for accommodating all SSs’ requests to both uplink and downlink

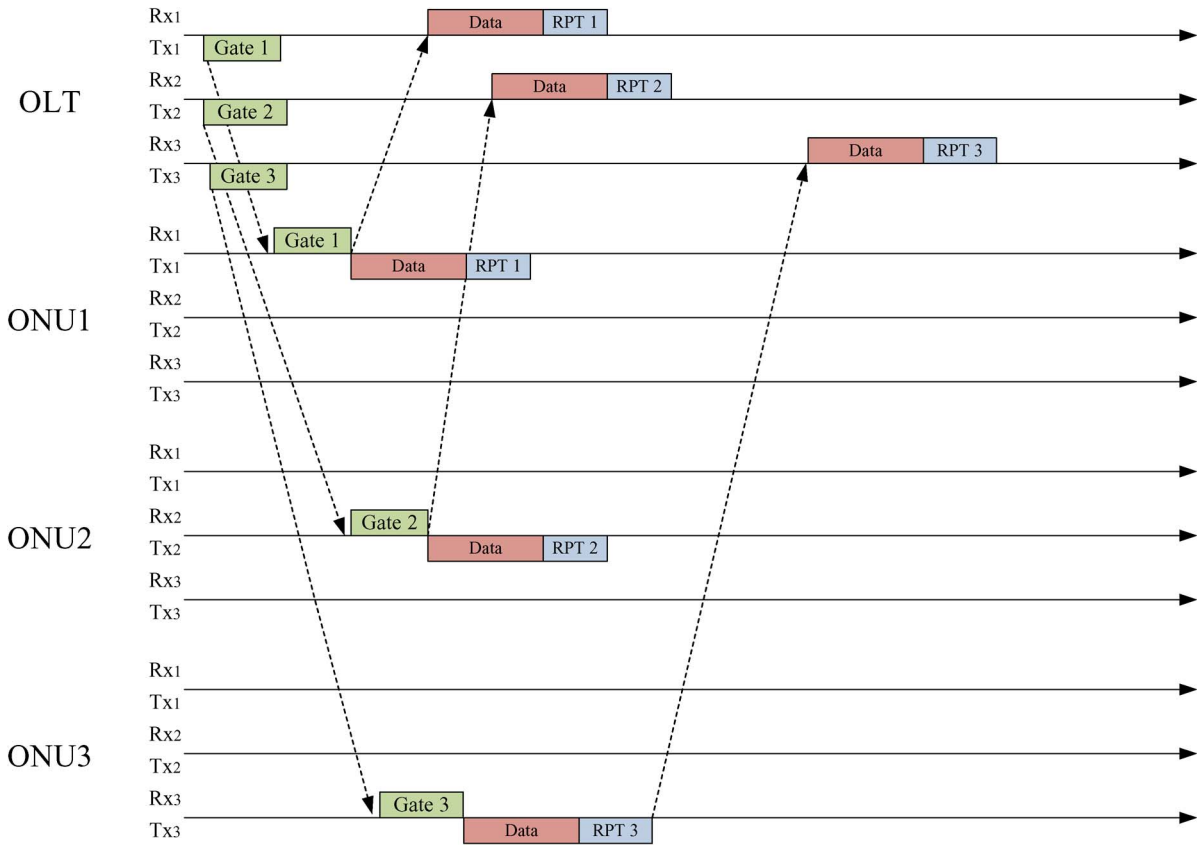

Fig. 7. The extended MPCP mechanism in a three-channel WDM-EPON.

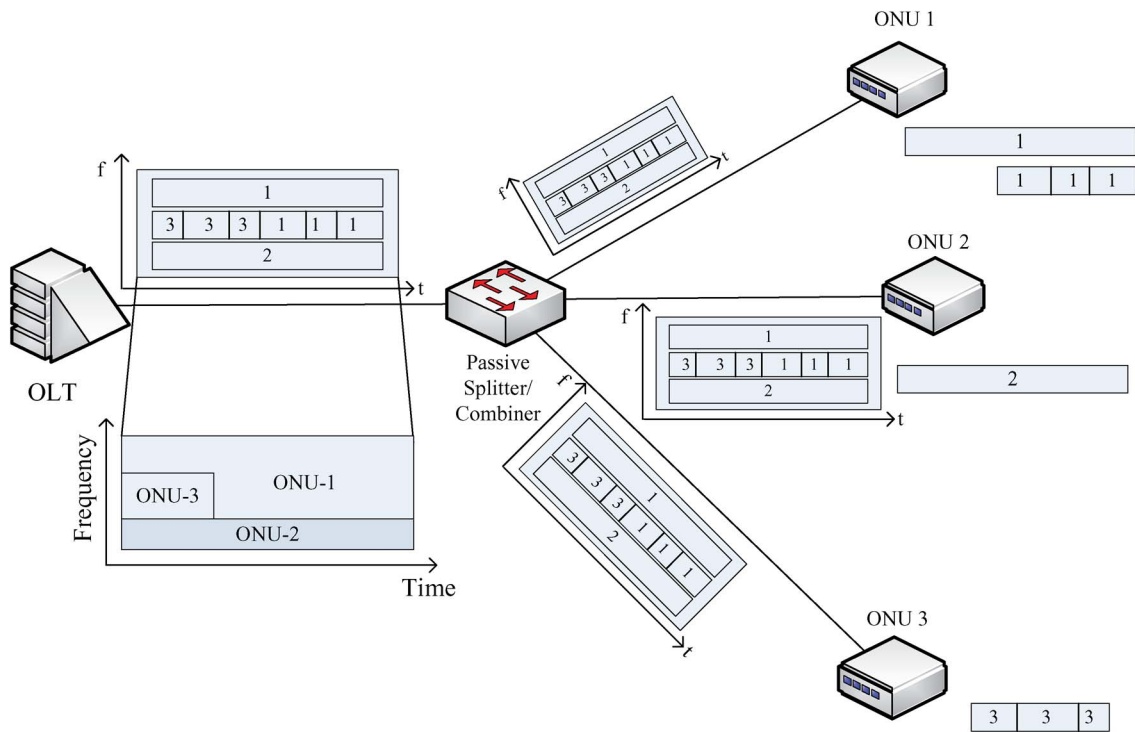

Fig. 8. A generic OFDM-PON with three ONUs.

sub-frames. For the downlink sub-frame, the BS decision is based on the needs and characteristics of the incoming traffic, while for the uplink sub-frame allocations are based on requests

originating from the SSS. A preamble section is initiated to synchronize the BS with the SSS. Various control information follow such as the broadcasted DL-MAP and UL-MAP MAC

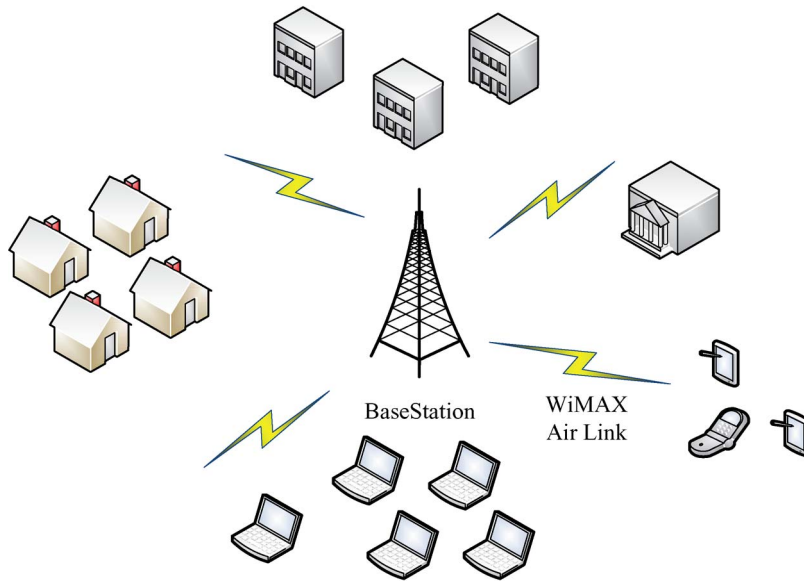

Fig. 9. A WiMAX access network.

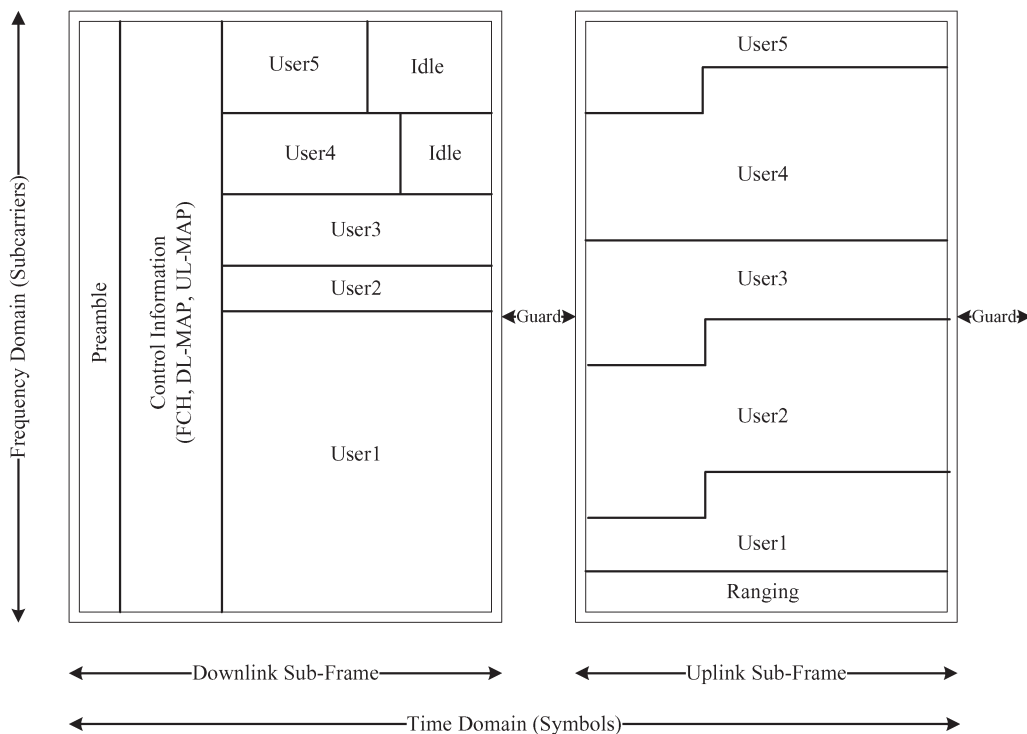

Fig. 10. Bandwidth allocation in WiMAX systems using the TDD technique.

management files which define the access to the downlink and uplink information respectively. The frame control header (FCH) specifies the burst profile and length of at least one downlink burst immediately following. Afterwards, user bursts are accommodated. A guard period protects both sub-frames from interferences. Uplink user bursts follow in the uplink sub-frame. Lastly, the ranging field performs channel conditions test to adaptively adjust radio physical characteristics. Efficiently utilizing the available bandwidth through the OFDMA technique constitutes an open and active area of research, since the standard does not include specific algorithms [43].

QoS provisioning is one of the essential features in IEEE 802.16 standards. For proper allocation of bandwidth, five services are defined to support different types of data flows: a) unsolicited grant service (UGS) is designed to support real-time CBR traffic such as VoIP; b) real-time polling service (rtPS) is designed to support VBR traffic such as MPEG video, c) non-real-time polling service (nrtPS) is for delay-tolerant data service with a minimum data rate, such as FTP, d) extended rtPS supports real-time service flows that generate variable size data packets on a periodic basis, and e) best effort (BE) service does not specify any service related requirements.

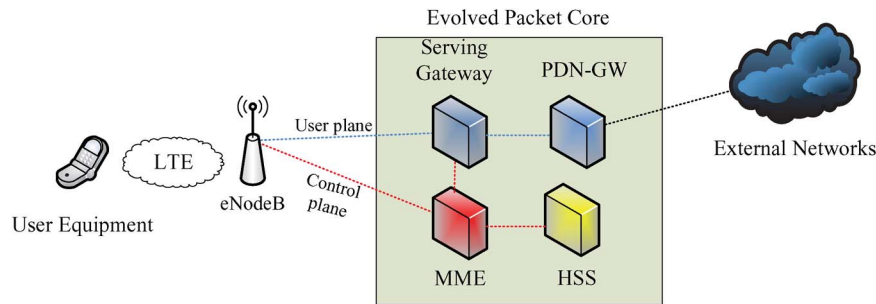

Fig. 11. The basic LTE access network.

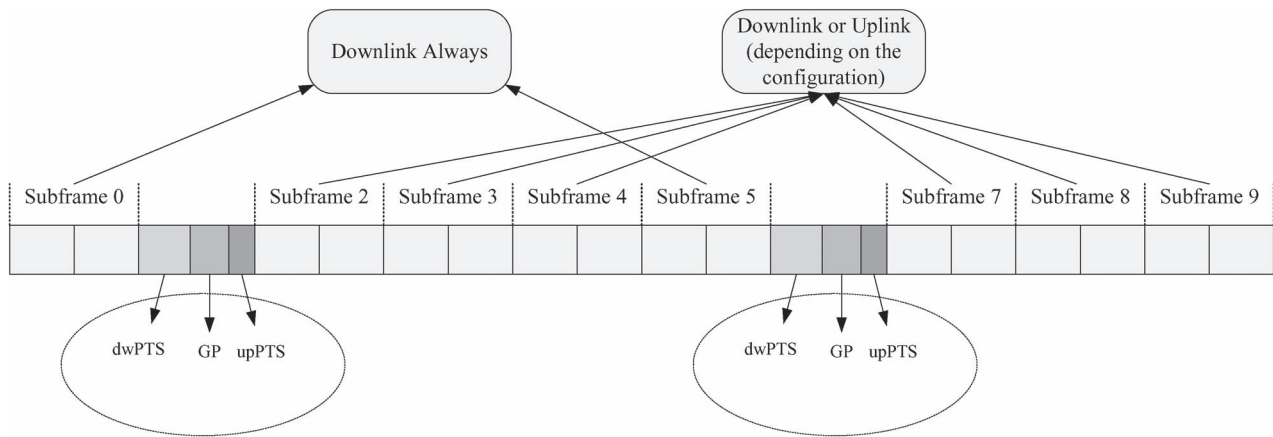

Fig. 12. A typical TDD LTE frame.

C. LTE Network

Long term evolution (LTE) mobile communication systems have been deployed as a natural evolution of global system for mobile communications (GSM), which is considered as 2G technology, and universal mobile telecommunication systems (UMTS), which is considered as 3G technology [10]–[13]. On October 20th 2010, the LTE Release 10 & Beyond (LTE-Advanced) was accepted as a 4G technology [44], [45]. This progress proves that the LTE-Advanced technology is one of the most active and promising research areas that worth extended attention to be as complete as possible when reaching the market, so that it will be successfully embraced by society.

Resource allocation to different user equipment (UE) inside a frame is a cross layer issue since it combines PHY layer features with MAC operations. Thus, it greatly depends on the underlying PHY layer specifications. The legacy LTE technology, as described in [44], [45], defines that resources are allocated in time and frequency, according to the principles of the OFDMA scheme for the downlink frame and the single-carrier FDMA (SC-FDMA) scheme for the uplink frame.

As in WiMAX, LTE is enhanced with a buffer reporting mechanism. It aims at informing the uplink scheduler about the requested (buffered) data at the UE. This mechanism consists of triggering and reporting events. The triggering event can be periodic or regular [46].

The main module of the LTE system is the evolved packet core (EPC). Fig. 11 shows an elemental architecture of the EPC when the UE is connected to the EPC over E-UTRAN (LTE access network) [10]–[13]. EPC was first introduced by

3GPP in Release 8 of the standard. It separates the user data, illustrated as user plane in the Fig. 11, and the signaling, depicted as control plane, to provide transparent architecture. The evolved NodeB (eNodeB) represents the BS in the LTE infrastructure. Four entities compose the EPC structure, namely a) serving gateway (Serving GW), b) PDN Gateway (PDN GW), c) mobility management entity (MME), and d) home subscriber server (HSS). EPC is connected to the external networks, which can include the IP multimedia core network subsystem (IMS).

The gateways (Serving GW and PDN GW) deal with the user plane. They transport IP data traffic between the UE and the external networks. The Serving GW is the point of interconnection between the infrastructure and the EPC. Its main role is to forward the incoming and outgoing IP packets from and to UE. The MME deals with the control plane. It handles the signaling related to mobility and security for E-UTRAN access. The HSS is a database that contains user-related and subscriber-related information. It also provides support functions in mobility management, call and session setup, user authentication and access authorization.

The bandwidth allocation takes place in uplink and downlink sub-frames. The LTE frame consists of two sub-frames of equal length, i.e., 5 ms each. Each sub-frame includes eight slots plus the three special fields, i.e., the downlink pilot time slot (DwPTS), the guard period (GP), and the uplink pilot time slot (UpPTS). Each slot is 0.5 ms in length and two consecutive slots form exactly one sub-frame. Fig. 12 illustrates a typical TDD LTE frame. It is obvious that the frame specifications are dramatically depend on the configuration. Each user receives

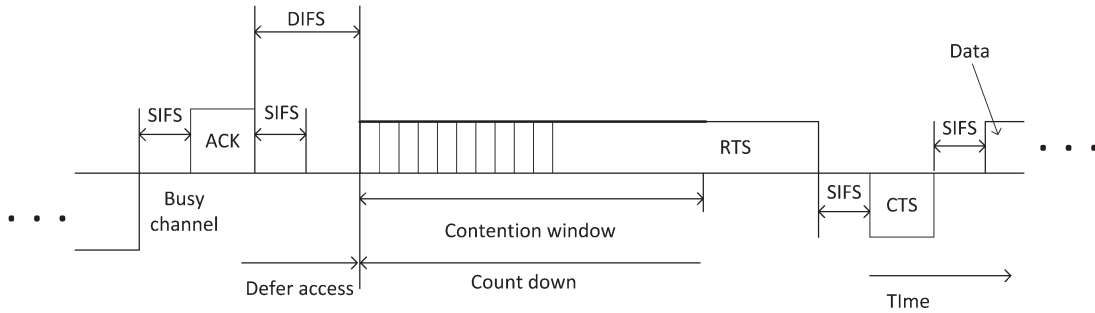

Fig. 13. A typical channel access scheme in legacy 802.11 networks.

small resource units known as symbols. Scheduling algorithms defines the way of distributing the available symbols to users in both directions.

The QoS provisioning in LTE standard engages the term of bearer, which is a packet flow established between the PDN-GW and the user terminal. A service can be differentiated into separate service data flows (SDFs). SDFs mapped to the same bearer receive a common QoS treatment. A bearer is assigned a scalar value referred to as a QoS class identifier (QCI), which specifies the class to which the bearer belongs [46]. QCI refers to scheduling metrics such as priority weights, admission control (AC) thresholds, and queue management indices.

D. WiFi Network

The most widely used wireless local area network (WLAN) standard is the 802.11 protocol released by IEEE, mainly due to its flexibility, mobility support, unlicensed frequency band, low cost, and connectivity provisioning, which requires minimal changes to the legacy infrastructure. The IEEE 802.11 specifications are detailed and address both MAC and PHY related issues [15]–[17].

The legacy 802.11 MAC protocol is based on carrier sense multiple access (CSMA). The core access mechanism is called distributed coordination function (DCF). It constitutes a listen-before-talk scheme, where a (wireless) station determines individually when to access the medium. Due to the nature of the CSMA collisions may occur. To reduce the probability of collisions, the DCF applies a collision avoidance (CA) mechanism. According to CA stations perform the so called backoff procedure before beginning transmission. If a station detects the medium as idle for a specific duration called DCF interframe space (DIFS), it keeps sensing the medium for an additional random time called backoff time. A station begins transmitting only if the medium remains idle for this time. Obviously, this procedure entails contention periods, where all stations contend for access by sensing the medium before transmitting. The duration of each backoff time is determined by each station individually. An optional enhanced mechanism is the request-to-send/clear-to-send (RTS/CTS) aiming at mitigating the hidden station problem. The hidden station problem refers to a scenario where a station (the “hidden” station) is not able to detect ongoing transmission of other stations because of radio channel conditions [47]. The RTS/CTS enforces each station to transmit a short RTS control frame, before the transmission, followed by the CTS control frame transmitted by the receiving

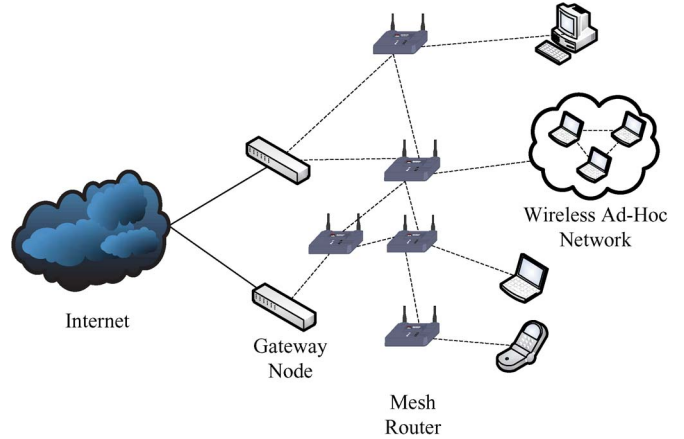

Fig. 14. A wireless mesh local area network.

station. The RTS and CTS frames include information on how long it will take to transmit the next data frame. Between two consecutive frames the short interframe space (SIFS) sets the transceiver inactive. Fig. 13 illustrates a typical channel access scheme in legacy 802.11 networks.

The (extended) IEEE 802.11e standard introduced substantial innovations to enhance the system efficiency and provide QoS support for delay sensitive applications and traffic. When an access point (AP) is employed, the WiFi architecture is called infrastructure and QoS provisioning could be realized. In particular, IEEE 802.11e defines the hybrid coordination function (HCF) which comprises two methods for channel access addressing QoS provision. The first is implemented by HCF controlled channel access (HCCA), requiring a central coordination instance that schedules medium access. The second is the enhanced distributed channel access (EDCA) that provides differentiated services among contending stations. The EDCA provides a QoS to higher priority access controls (ACs), according to which AC3 and AC0 are the highest and lowest priority ACs, respectively. However, due to the probabilistic nature of channel access, hard QoS guarantees such as strict delay bound cannot be provided.

Nonetheless, the mesh topology is often used to extend the network visibility. Fig. 14 illustrates a typical WLAN in mesh topology. Various mesh routers are deployed to cover as much as possible geographical area. The main objective of the mesh topology is to provide wireless interfaced users with connectivity to the Internet. Obviously, this way of interconnecting users creates multiple wireless paths to the gateway(s) forming

TABLE I
COMPARISON OF ENABLED OPTICAL AND WIRELESS TECHNOLOGIES

| | Technology | Channel (s) | Flexibility | Bandwidth Capabilities | Multiplexing | Standardized |
|-------------------|-------------|---|-------------|------------------------|--------------|--------------|
| Optical Backhaul | EPON/GE-PON | Two (one for upstream and one for downstream) | Low | Medium/High | TDM | Yes |
| | GPON/XG-PON | Two (one for upstream and one for downstream) | Low | Medium/High | TDM | Yes |
| | WDM-PON | Multiple | Medium | High | WDM | No |
| | OFDM-PON | Sub-channels | High | High | OFDM | No |
| Wireless Backhaul | WiFi | Sub-channels | Medium | Low | DSSS/OFDMA | Yes |
| | WiMAX | Sub-channels | High | Low/Medium | OFDM | Yes |
| | LTE | Resource blocks | High | Low/Medium | OFDM | Yes |
| | Mesh WiFi | Sub-channels | Medium | Low | DSSS/OFDMA | Yes |

a wireless routing network. In this case, finding the optimal routing path and determining appropriate routing criteria, such as applying energy-aware algorithms, for interconnecting each user to the Internet prevail over QoS provisioning.

E. Architecture Comparison

To better perceive the merits and the limitations of each access architecture, a comparison follows in terms of available channels, flexibility, bandwidth capabilities, multiplexing technique, and (standard) compliance. (G)E-PON and (X)G-PON architectures utilize two channels, one for each direction. WDM-PON systems support many channels in a pay-as-you-grow logic. This means that the service provider is able to add/remove channels depending on the population density or/and the variety of the supported services. OFDM-PON, WiMAX, and LTE systems support sub-channelization due to their underlying OFDM multiplexing technique. However, OFDM-PONs offer sub-channels that support quite more bit rates than the respective wireless systems. Most of legacy IEEE 802.11 radio interfaces support OFDM (802.11a, 802.11g, 802.11n, 802.11ac, and 802.11ad) and provide multiple low-bandwidth channels. On the other hand, IEEE 802.11b supports direct-sequence spread spectrum (DSSS), where the transmitted signal occupies more bandwidth than the information signal that modulates the carrier or broadcast frequency. The flexibility issue is related to the ability of flexible (or elastic) bandwidth allocation. Based on this metric, OFDM-PONs, WiMAX, and LTE manage to effectively distribute the available OFDM resources since each user is capable of receiving very small resource units (symbols). In terms of bandwidth capabilities, the optical architecture excels, as expected. NG-PONs endeavor to offer symmetrical 10 Gb/s rate, while all wireless interfaces are dramatically affected by the existing channel conditions, the distance between the SS and the BS, and the population density of each BS/cell. Regarding the standardization aspect, WDM-PON and OFDM-PON systems have not yet been standardized. All other architectures are standard-compliant. Table I summarizes the aforementioned aspects, while Table II provides helpful definitions and background to the reader.

IV. FiWi NETWORKS

The integration of optical and wireless technologies to cohere a broadband access network is mostly denoted as FiWi. This notation is adopted in this article. A multitude of wireless-optical frameworks can be found in the literature that may be grouped into two main categories in terms of magnitude of integration. The first one, namely *radio over fiber (RoF)* focuses on PHY layer integration. Radio frequencies (RFs) are carried over analog optical fiber links between the CO and multiple remote antenna units (RAUs). The clients use the RAUs to send and receive data through the air. The second category consists of hybrid wireless-optical architectures, aiming at integrating optical and wireless technologies in both PHY and MAC layers. This paradigm is called *radio and fiber (R&F)* and entails discrete optical and wireless networks composing a single hybrid wireless-optical network keeping their subtle features untouched.

RoF technology is not a new approach in wireless-optical integration area. Nevertheless, its research begun many years ago inaugurating several substantial enabling technologies such as optical RF generator, remote modulation and multiplexing [48]–[50]. The primary purpose of existing *RoF* works is related to the exploration of the PHY layer, namely, modulation techniques and *RoF* transmission features. The functionality, and therefore, the complexity of RAUs is low, since the overall signal processing function and the resource allocation policy are in charge of CO reducing the cost of RAUs and the overall power consumption.

Nonetheless, *RoF* performance is limited when a distributed MAC protocol such as IEEE 802.11b is used in the wireless part of integrated network. This occurs due to the existence of additional propagation delay between wireless subscriber and AP in IEEE 802.11 a/b/g frameworks. Moreover, the centralized function of *RoF* may cause possible bottleneck in the hybrid access network, since the traffic generated from users at wireless part travels towards the optical network. As a consequence, a possible CO failure will affect the whole network performance. Based on the aforementioned remarks, *RoF* networking has low practical value and it is deemed out of scope of this work.

TABLE II
DEFINITIONS AND BACKGROUND

| Term | Definition | Role |
|---------------------------------|--|--|
| Bandwidth Allocation | Bandwidth allocation is defined as the process of granting individual transmission opportunities to the users. | This process governs the distribution of the available bandwidth in terms of Bytes, timeslots, channels, and sub-carriers to the users connected to the network. |
| QoS | QoS is the process of providing guarantees on delivering network traffic in final users in terms of throughput, delay, packet drop ratio and jitter. | The role of the QoS in communication networks is to attain a high level of data delivered according to the users' SLAs. |
| Downstream Direction | When traffic is carried out from the backbone to the final users the downstream direction (flow) is formed. | The downstream direction is utilized by the network entity that arbitrates the bandwidth distribution stemming from the backbone (internet) in order to deliver data from the backbone to the final users. |
| Upstream Direction | The uplink flow is formed as the traffic goes towards to the backbone network stemming from the final users. | The upstream direction is utilized by the network entity that arbitrates the bandwidth distribution, stemming from the final users, in order to deliver data to the backbone (Internet) |
| DBA in PONs | The term DBA is defined as the dynamic bandwidth allocation conducted by the OLT | In PONs the bandwidth allocation process is conducted by the OLT, which is the core arbitrator in the system. In the most cases, the term DBA in PONs is associated with the upstream direction. |
| DBA in Wireless Backhaul | The term DBA is not so popular in wireless access networks. The term scheduling or (traffic) reservation is more formal alternatively. It incorporates the bandwidth distribution to the wireless clients conducted by the base station. | In wireless access networks the scheduling/reservation process entails the sharing of the available resources of the radio interface to the connected wireless clients. It involves both directions. |
| Inter-ONU Scheduling | Inter-ONU scheduling is responsible for arbitrating the transmission of different ONUs by the OLT. | The OLT distributes bandwidth to the ONUs based on their traffic requests. |
| Intra-ONU Scheduling | Intra-ONU scheduling is responsible for arbitrating the transmissions of different priority queues in each ONU | An arbitration entity, e.g., the OLT or the ONU, handles the data packets in accordance with their sensitivity in terms of traffic class priority. |
| Scheduling in PONs | The term scheduling in PONs implies intra-ONU packet scheduling. | It grants transmission opportunities to the data packets based on their priority. |

On the other hand, R&F framework is capable of addressing the mentioned limitations by using different MAC protocols in the two domains resulting that the optical and wireless media are handled by separate MAC controller. Thus, the wireless frames simply reach their corresponding AP avoiding reaching the optical part for processing by CO. In general, R&F architecture may be formed in two different platforms based on the service provisioning orientation. We call the first form as *hybrid wireless-optical mesh networking*, where multiple connected wireless nodes expand the network range in an ad-hoc basis. The most representative paradigm that falls into this category is the *WOBAN* [51]–[54]. The *WOBAN* paradigm provides several wireless routers and a number of gateways connected to the ONUs, and through the OLT, to the rest of the Internet. It aims at providing optimal routing to navigate data packets across the mesh network. At the same time, it performs efficient ONU and gateway deployment within the network [51]–[54]. We denote

the second form as *hybrid wireless-optical access networking*. In this class, we classify hybrid network architectures that employ a single wireless BS, directly connected to the optical domain, mostly, via the ONU unit. Paradigms of this category engage integration of various PON frameworks with broadband wireless technologies such as WiMAX, LTE, and WiFi, as discussed later in this article. Fig. 15 summarizes this taxonomy.

This survey mainly investigates the research conducted towards the R&F development, since it recently receives the most attention and offers tighter integration of the two technologies.

V. INTEGRATION OF ONU & BS

This Section provides insights in the interconnection of the optical and wireless architectures. Bearing in mind that the vast majority of R&F architectures entails that the PON framework constitutes the core optical domain, the most promising and

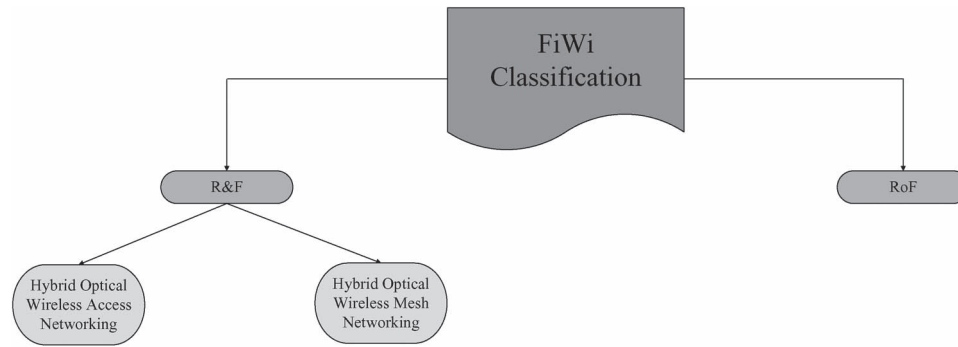

Fig. 15. Classification of fiber-wireless networks.

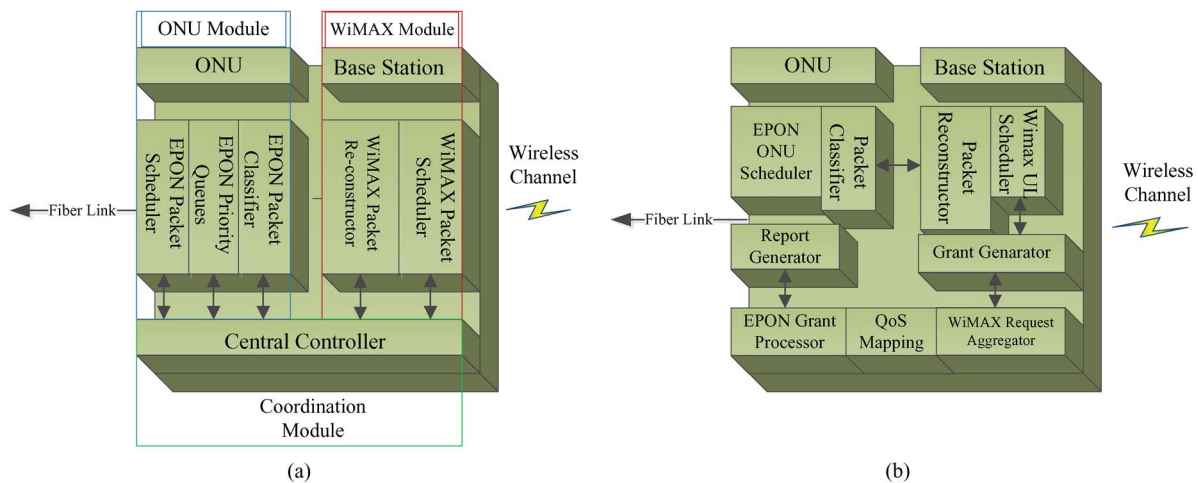

Fig. 16. (a) Hybrid architecture and (b) combined architecture.

cost-efficient solution to implement hybrid wireless-optical networks enhances the ONU with wireless interface, i.e., attaching a wireless BS to the ONU.

The initial concept behind the integration of optical and wireless domains lies in the simple and independent communication of ONU and BS by means of Ethernet interface. This initial architecture is called *independent* and constitutes the basis for the subsequent approaches. A substantial modification of independent architecture inaugurates the hybrid architecture aiming at reducing the implementation cost. In parallel, by integrating the ONU and the BS into a single device, the vision of providing more efficient bandwidth allocation operation is met. In the same context, the *combined architecture* offers even more effective QoS provisioning by inserting a central control module between the ONU and BS. By modifying the EPON MAC layer protocol, to further supporting the connection-oriented services, the *unified architecture* provides QoS with acceptable delay without involving additional control frames. An alternative approach, defined as *microwave over fibre architecture*, leverages the great capacity of fiber, by exploiting the microwave-over-fibre modulation. Concurrently, it manages to reduce the implementation cost. Lastly, the main purpose of software-based architecture is to provide a simple, cost-effective way to virtually analyze the involved protocols and infrastructures.

In the following, we identify the various techniques and implementation options towards the implementation of the enhanced ONU.

A. Independent Architecture

The simplest way of implementing the integration of ONU and BS is the *independent architecture* [55]. This framework implies that both devices are connected independently, e.g., by using a single cable. Hence, a common protocol is required for facilitating the intercommunication process. Employing the Ethernet as the common interface protocol offers the advantage of need no special requirements for implementing the independent architecture. The bandwidth allocation process and packet forwarding are independently managed at both optical and wireless parts. For instance, regarding the upstream direction, SSSs send their data packets to their associated BS and the latter forwards the packet to its connected ONU. In the optical domain, ONU encapsulates and forwards the received packet to the OLT and *vice versa*.

B. Hybrid Architecture

To further enhance the integration, the BS and ONU can be considered as single system components, enabling a deep integration in aspects of software and hardware. This type of integration is called *hybrid architecture*. The authors in [56] inaugurate the hybrid architecture by integrating an EPON ONU with a WiMAX BS. Three modules are placed into the single integrated box. Fig. 16(a) illustrates the inner structure of the single device. The first module governs the ONU processes. In particular, it realizes the EPON packet scheduler, which is a

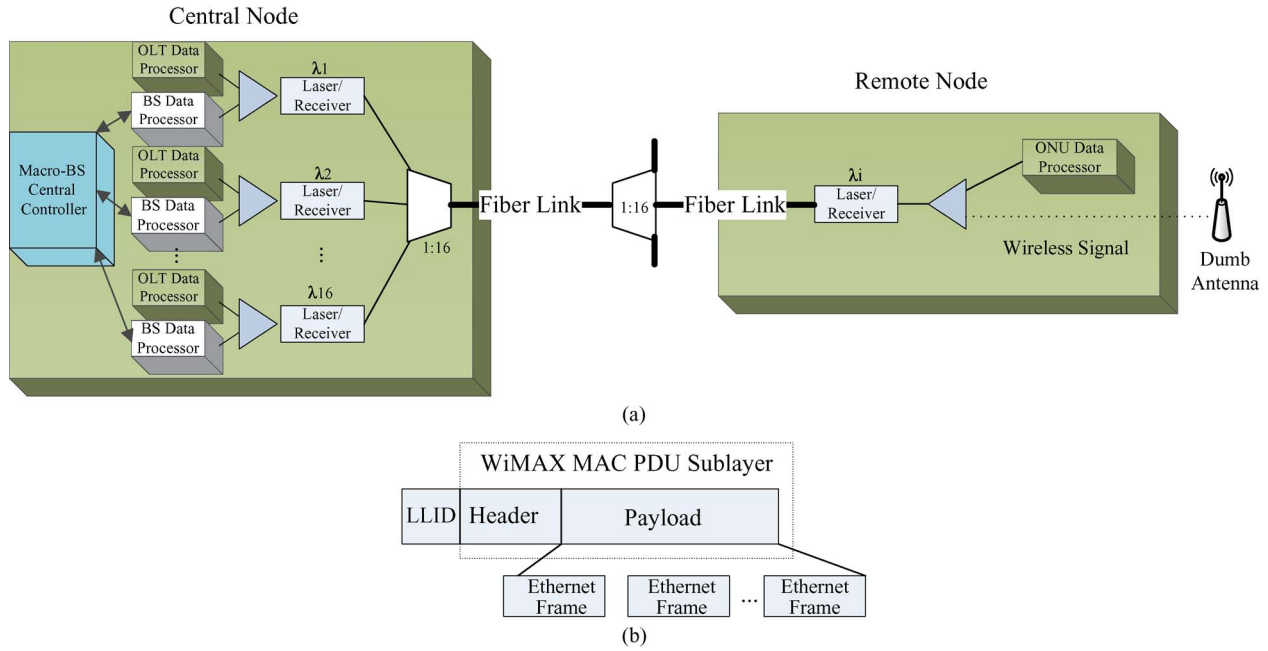

Fig. 17. (a) MoF architecture and (b) unified architecture.

functional component responsible for forwarding the packets from the embedded ONU to the OLT. Also, it applies QoS provisioning by handling priority queues and packet classification. The second module manages the BS tasks, such as the WiMAX packet re-constructor and scheduler, while the third module supports the coordination and guarantees the efficient operation of the whole system. The aforementioned architecture and its variations present notable advantages, since they define a single ONU-BS device and therefore have been adopted by many proposed integrated schemes [57]–[60].

C. Combined Architecture

Another architecture paradigm, known as *combined architecture*, is proposed in [61]. In this case the ONU and the BS compose a single device, where a central control module, namely the *joint controller*, is located between them. Fig. 16(b) depicts the joint controller structure. The joint controller manages the integrated QoS application as well as the bandwidth allocation process by means of three functional modules, namely a) the EPON grant processor module, b) the WiMAX request aggregator module, and c) the QoS mapper module. EPON grant processor is destined to data packets transmission. Since the WiMAX communication process is connection-oriented, the WiMAX request aggregator is responsible for collecting the requests generated by SSs in a connection-oriented manner. Lastly, the QoS mapper module aims at handling different QoS mechanisms among EPON and WiMAX.

D. Unified Architecture

Taking advantage of the quite similar operation of EPON and WiMAX, in terms of bandwidth allocation, a unified protocol operation seems to be feasible. In spite of their similarities, EPON and WiMAX use different operational protocols. EPON

bandwidth requests are queue-oriented, which means that each ONU allocates the granted bandwidth to up to eight different priority queues in the ONU. In contrast, WiMAX employs a connection-oriented fashion, where the amount of bandwidth granted to SS is allocated to each service connection linked to the SS. Generally, WiMAX connection-oriented approach supports more efficient QoS, because it shows more predictable QoS than the queue-oriented approach. Based on this argument, the concept behind the *unified connection-oriented architecture* (UCOA) lies in the modification of EPON MAC layer mechanism. This is attached to the need for cooperation with the WiMAX connection-oriented MAC layer [55]. In particular, EPON data frames are encapsulated into WiMAX protocol data units (PDUs) and then they are transmitted over the PON. A new sub-layer is inserted to allocate bandwidth in the optical network part. Fig. 17(b) illustrates the frame transmitted between OLT and ONUs over the PON after the encapsulation of Ethernet frames into WiMAX MAC PDUs. The logic link ID (LLID) field is used for preamble and addressing MAC links. A salient benefit is that the whole integrated operation is managed by a consolidated protocol offering simplification in operation and efficient QoS provisioning.

E. MoF Architecture

In all the aforementioned architectures, traffic coming from both optical and wireless domains is transmitted using the fiber baseband. To better utilize the fiber spectrum, an integrated architecture which applies the *microwave over fibre (MoF)* [62] modulation has been proposed in [56], called *microwave over fibre architecture (MOFA)*. The WDM technique is utilized to concurrently modulate baseband with WiMAX signals in a single fiber. Fig. 17(a) shows a MoF architecture operating under a WDM PON. In essence, this architecture consists of remote nodes and a central node. Each remote node is equipped with an

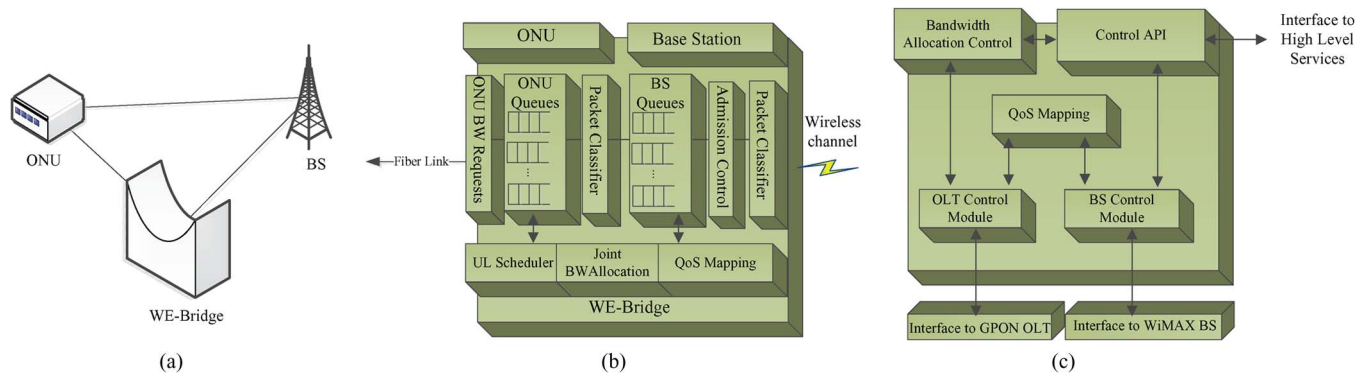

Fig. 18. (a) General layout of WE-Bridge, (b) functional modules of WE-Bridge in [63], and (c) software-based system architecture of the control bridge in [64].

ONU data processor unit, managing the data generated from WDM PON, and a dumb antenna that transmits the radio WiMAX signal to its associated micro-cell. The two separate signals are multiplexed and modulated over a common optical frequency and transmitted to the central node. An equal number of OLTs and WiMAX BSs, e.g., 16 OLTs along with 16 BSs are located in the central node. In particular the BSs are connected with the so-called macro-BS, which handles the traffic originated from the associated micro-cells. At the same time, it coordinates the function of each WiMAX BS. The operation of the central node takes place in the reverse way. The incoming optical signal is demultiplexed into different wavelengths, and after converting it to electronic format, the signal is again demultiplexed into separate baseband and WiMAX signals.

F. Software-Based Architecture

The usage of a *software-based bridge* may facilitate the wireless-optical integration. In [63], [64] the authors endeavor to demonstrate a software-based bridge placed between the ONU and the BS. Such a deployment offers a virtually integrated infrastructure by applying a WiMAX-EPON bridge (WE-Bridge) in the aspect of controlling the whole bandwidth allocation process. Fig. 18(a) displays the general layout of the WE-Bridge. The functional module of the WE-Bridge is illustrated in Fig. 18(b). A brief description of the most important parts of the module follows:

- Packet classifier: it classifies the uplink data into a set of classes. It is noted that WiMAX supports five classes while EPON holds up to eight priority queues.
- QoS Mapping module: it maps the BS packets into ONU queues and, at the same time, it ensures that the QoS requirements during the BS to ONU mapping and vice versa are met.
- AC module: it applies the policy regarding the AC of user's type traffic.
- ONU BW request module: once the packets are mapped into the ONU queues, ONU BW request module is in charge of requesting bandwidth according to queues' needs.
- Joint BW allocation: it controls the bandwidth reservation and supports the QoS between EPON and WiMAX systems.

In the context of the software-based architectures, an alternative control bridge is proposed in [64]. Fig. 18(c) shows this framework that associates GPON and WiMAX systems. Mainly, the control bridge intends to provide an efficient integrated QoS mapping and provisioning block, as described later in this article.

G. Discussion and Remarks

In this sub-section, a qualitative assessment of the presented architectures is attempted. The crucial issues of a) equipment cost, b) implementation complexity, c) QoS supporting and d) scheduling are discussed and analyzed.

The independent architecture excels in terms of simplicity. It offers direct interconnection without necessitating laborious requirements and maintenance. In addition, the independent architecture is considered as a standardized paradigm using a common Ethernet interface in both optical and wireless domain. The equipment cost is probably higher than the architecture using the hybrid ONU-BS single box because it uses two separate devices (ONU and BS). However, the main limitation of the independent architecture is the bandwidth allocation and the QoS provisioning processes. To be more precise, the bandwidth allocation process in optical and wireless part occurs independently. As a consequence, the ONU and the BS are not able to share either the essential knowledge about the BS packet scheduling or the information regarding the upstream data scheduling of the ONU to OLT. Therefore, the independent architecture presents impairments in handling critical processes such as the bandwidth allocation.

In the aspect of hybrid paradigm, the bandwidth allocation is leveraged by providing global knowledge regarding packet delivery across the network. For instance, a hybrid ONU-BS is aware of the required real-time state information regarding the downstream packet scheduling and the upstream bandwidth requests in the whole network. Simulations conducted in [65] demonstrate that the hybrid architecture exhibits lower delay in terms of rtPS service type compared to the independent and unified architectures as the traffic load is getting more pressing. This is attached to the data transparency enabled by the ONU-BS. In terms of equipment cost, hybrid architecture is a relative cost-effective solution, since the ONU and the BS form a single device. Nevertheless, the efficiency of the above solution may be degraded when only few ONU-BS devices are

TABLE III
CLASSIFICATION OF INTEGRATED ARCHITECTURES

| | Equipment cost | Implementation complexity | Standardized | QoS provisioning | Integration level | Scheduling |
|-----------------------------|----------------|---------------------------|--------------|------------------|-------------------|------------|
| Independent | High | Low | Yes | Low | Low | Low |
| Hybrid | Medium | Medium | No | High | High | High |
| Combined | Medium | Medium | No | High | High | High |
| Unified | Medium | High | No | High | High | High |
| Microwave-over-Fiber | Medium | High | No | Medium | High | Medium |
| Software-based | Low | Low | Yes | Medium | Low | Medium |

used. The implementation cost of the combined architecture is considered quite higher than the hybrid one, because of the cost added owing to the installation of the new customized joint controller module. Similar to the hybrid paradigm, the centralized scheduling, adopted by the combined approach, seems more effective on applying bandwidth allocation. According to [61], the combined approach offers good bandwidth utilization and QoS provisioning. As far as the unified architecture is concerned, an interesting feature is identified. It appears that there is no need for control frames in the context of bandwidth allocation. Moreover, it can provide QoS support with tolerable delay in delay-sensitive services [65].

The main benefit of the MoF platform lies in its in low implementation cost. For instance, a single macro-BS and a dumb antenna are enough to support adequate WiMAX bandwidth allocation. Given that the macro-BS manages all the micro-cells, it possesses the full knowledge about their bandwidth demands, thus it can provide efficient bandwidth allocation and packet scheduling mechanisms. On the other hand, a possible failure either in fiber or in the central node will cause the whole network failure since the fiber carries out both the baseband and WiMAX signals. Moreover, the risk of causing a bottleneck in WiMAX network is high due to the centralized operation of macro-BS. As the macro-BS governs all wireless users it may suffer from high complexity.

Apart from independent, the above approaches suffer from a critical shortcoming; they are not standardized. Consequently, the market penetration of such prototypes could be laborious. Beyond their benefits, the unified and MoF architectures are bounded by the involvement of PHY interface adaption which may be costly and complicated. The software-based architecture seems to overcome the aforementioned downsides since it is relatively cost-effective, simple and standardized. However, under heavy traffic conditions the request process may induce deficiencies.

One interesting point is whether software architecture would implement other hardware-based architectures. To this end, software defined networking (SDN), a latest trend on efficiently handling network components and devices with software interfaces, could be the key player. SDN concept enables a programmable network control and offers a solution to a variety of use cases [66]. The most compelling cases for SDN-based modules are a) cloud orchestration, b) load balancing, c) routing, d) monitoring and measurement, e) network management, and f) application-awareness. Given that independent, hybrid, combined, and unified architecture incorporate network

management and routing tasks, e.g., interconnection between layers, encapsulation, and bridging, SDN interfaces could be able to provide management, traffic monitoring, and bridging services, thus partially or fully replacing the embedded hardware components. However, MoF architecture entails complex transceivers, special modulation components, and composite multiplexing device, hence the penetration of SDN interfaces in MoF inner design issues may be insufficient.

Table III summarizes findings on compiling the various aforementioned architectures.

VI. CONVERGENCE OF ENABLED TECHNOLOGIES

An integrated wireless-optical network may engage a variety of optical and wireless technologies. The substantial factors that govern the selection of the technologies involves the available budget, the geographical area (rural or urban), the required QoS, and issues related to the users, e.g., connection type, wired interface, mobile connectivity etc. Truly, in most of the converged technologies the hybrid architecture is adopted regarding the infrastructure of the embedded ONU. Optical technologies including TDM-PON, EPON, WDM-PON, G-PON, and OFDM-PON can be combined with WiMAX in access mode, WiMAX in mesh mode, WiFi in infrastructure mode, WiFi in ad-hoc mode and LTE wireless technologies. Leveraging the advantages of optical technologies, especially the high offered capacity, the optical part turns out to be the most suitable technology for the backhaul part of the integrated network. In the network's front-end point of view, the wireless technology offers low equipment cost and fixed, mobile broadband access networking. In addition, the majority of the up-to-date proposed converged networks utilizes optical technologies to support the backhaul part, therefore, the following presentation is classified based on the optical backhaul.

The taxonomy mainly includes a) EPON, b) WDM-PON, c) OFDM-PON, and d) G-PON as the core (optical) domain. The topologies enabled in the optical domain include optical ring, tree, and star. On the other hand, the wireless domain can be formed in either access or mesh network topology.

A fourth category considers the multi-stage of multiple different technologies creating a multi-function, wide-range network.

A. EPON Backhaul Network

Amongst PONs and wireless broadband access technologies, the Ethernet PON and WiMAX have been extensively

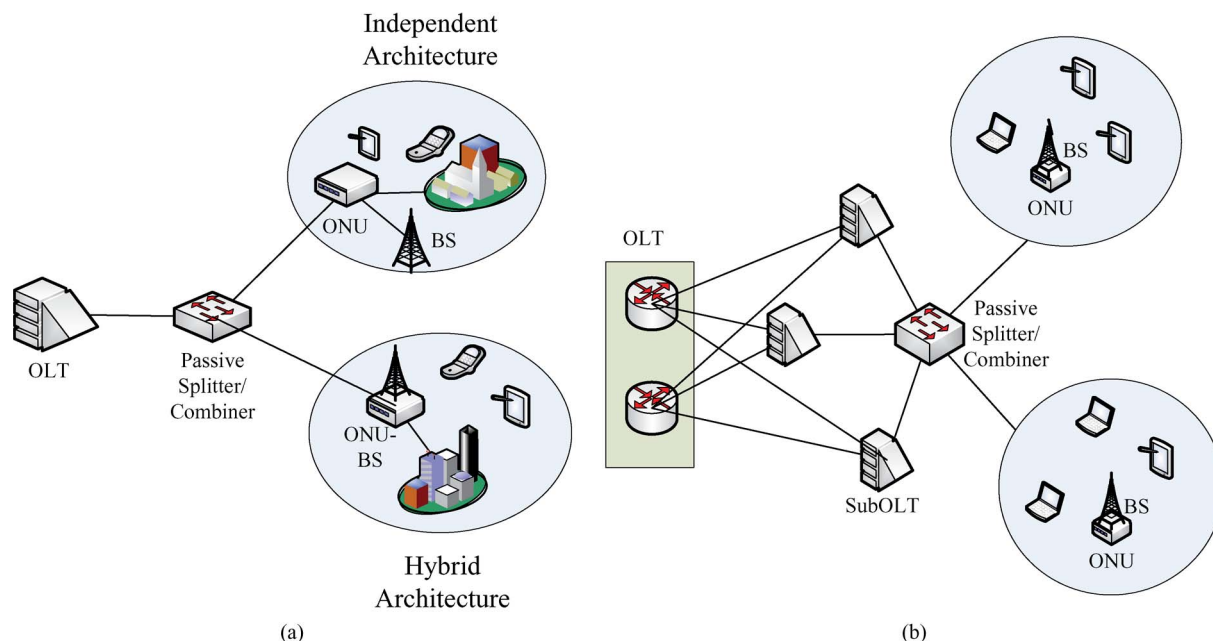

Fig. 19. (a) EPON-WiMAX architecture. (b) Optical-optical-wireless architecture incorporating EPON-WiMAX architecture.

considered as potential candidates for the wireless-optical integration. This is because both EPON and WiMAX networks share much similarity in bandwidth allocation and QoS support, based on a generic poll/request/grant mechanism. This similarity simplifies the integration. Both EPON and WiMAX systems request and allocate bandwidth in a similar manner, support services with different QoS levels, and classify data traffic in a differentiated services mode. This common way of operating facilitates the integration of bandwidth allocation and QoS support in EPON-WiMAX architectures. Assuring QoS of diverse applications in the wireless-optical converged networks still remains a challenge especially during network congestions. In particular, unlike in typical EPON, single ONU-BS serves many more SSs compared to an ONU which serves only few end users. Consequently, poor QoS performance of a single ONU-BS affects many SSs (SSs either can be wireless or wired), and the integrated network requires proper resource handling mechanisms. Fig. 19(a) shows a general network construction composed of the most popular EPON tree-based topology, where the EPON forms the backhaul part interconnected with WiMAX front end platform [55].

A different approach of EPON and WiMAX convergence, known as optical-optical-wireless (OOW), is proposed in [60]. As Fig. 19(b) illustrates, a number of sub-OLTs are placed between the OLT and ONUs forming a sub-network in which the corresponding sub-OLT has the functional role of the OLT. Each sub-OLT is connected to the OLT and to a group of ONUs, which in turn are connected to BSs by means of optical splitter. The OLT is equipped with two routers; the first one operates as the primary gateway for the sub-OLTs and the other is used by sub-OLTs in the case of congestion stemming from the primary router connection. The main idea behind the OOW lies in its capability of extending the network coverage of optical network by inserting the intermediate sub-network. The sub-network is managed by the corresponding sub-OLT, located between the

conventional backhaul and the front-end. The couple of routers residing at the OLT and the multiple sub-OLTs offer endurance against links or nodes failure.

Exploiting the capability of LTE to operate with high data rate, a possible integration network could be implemented by the convergence of EPON and LTE technologies. LTE network consist of a core network (CN), called EPC (as mentioned in Section III) and an access network composed of a new enhanced BS the so-called evolved nodeB (eNB). The specific integrated network is shown in Fig. 20. Therein, the ONU is enhanced with the EPC module [67].

A WOBAN is another compelling example of combining TDM-PON with either a WiFi or a WiMAX wireless mesh network [51]. Fig. 21 illustrates a typical WOBAN system containing different PON entities and two BS types, namely the gateway routers and the BS routers. Gateway routers are directly connected to an ONU, while BS routers are responsible for managing the mesh network. Thus, the front-end of a WOBAN is essentially a multi-hop wireless mesh network with several wireless routers and a few gateways connecting to the ONUs, and consequently, to the rest of the Internet through the OLTs.

B. WDM PON Backhaul Network

A WDM-PON network allocates a separate pair of dedicated upstream and downstream wavelength channels to each subscriber providing point-to-point high bit rate connectivity to each client, protocol transparency, and guaranteed QoS. A WDM-PON can be efficiently converged with WiFi-based mesh networks. It forms an optical unidirectional WDM ring [52]. Fig. 22 depicts this paradigm.

The network backhaul consists of an optical WDM ring equipped with single or multi-channel PONs. At the PON part, an OLT is connected to the WDM ring via an optical

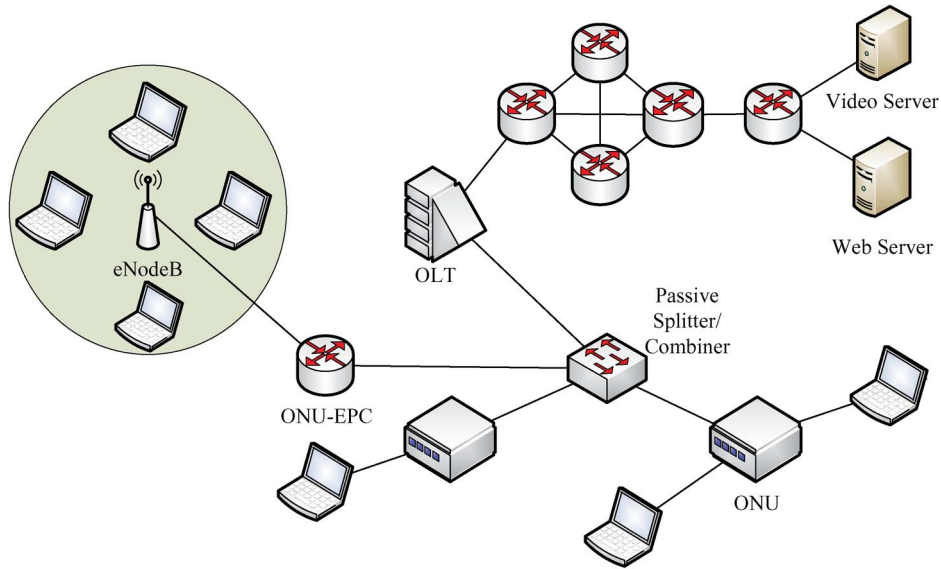

Fig. 20. EPON-LTE integrated network.

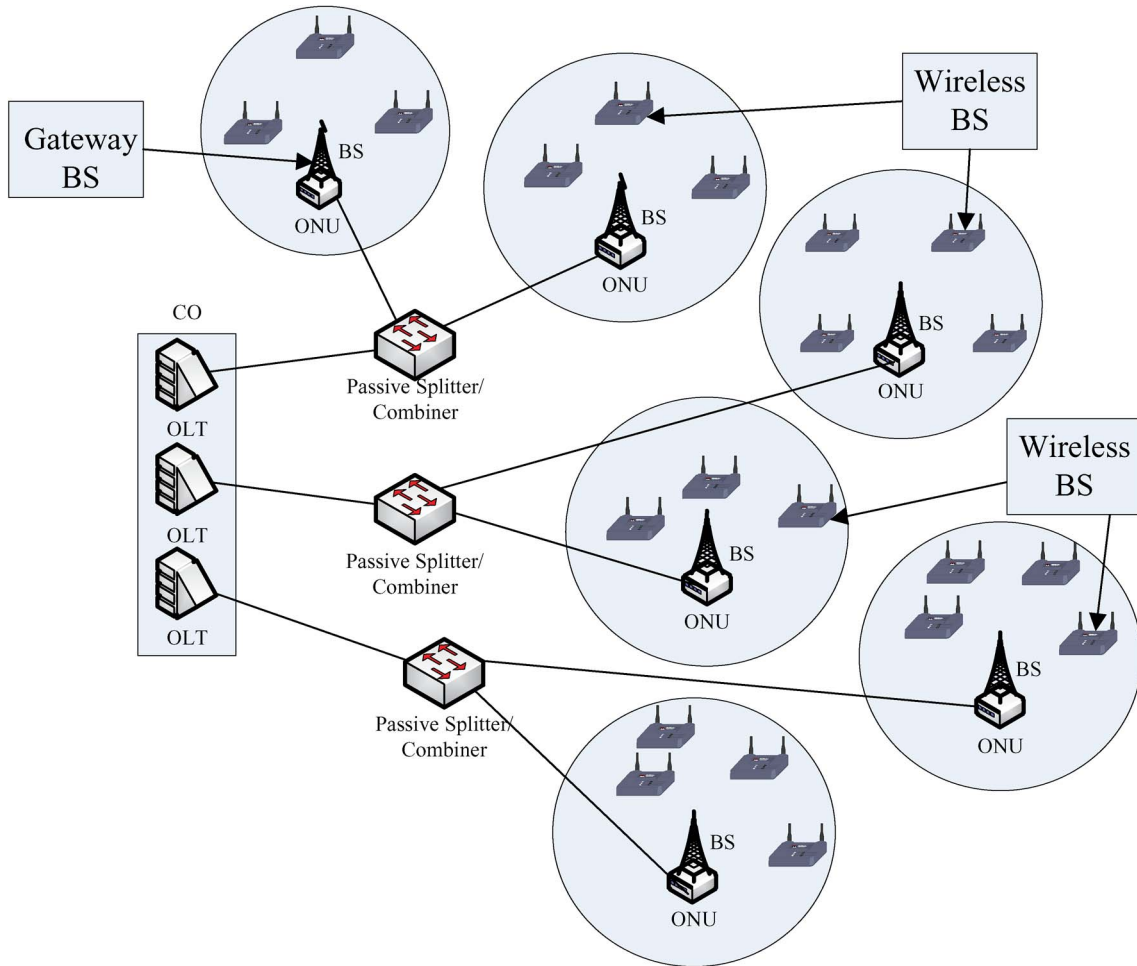

Fig. 21. A typical WOBAN system.

add-drop multiplexer (OADM). The interconnection of PONs and various mesh networks is achieved by means of wireless gateways located in mesh coverage.

An alternative cost-effective, scalable, and simple architecture is demonstrated by converging WDM-based PON with

LTE radio access network (RAN) [67], [68]. An instance of this network type is illustrated in Fig. 23. Each eNB is integrated with the corresponding ONU located at an optical ring, while the EPC is connected to the OLT. The proposed network [68] is able to support a number of OLTs resulting in incorporating a

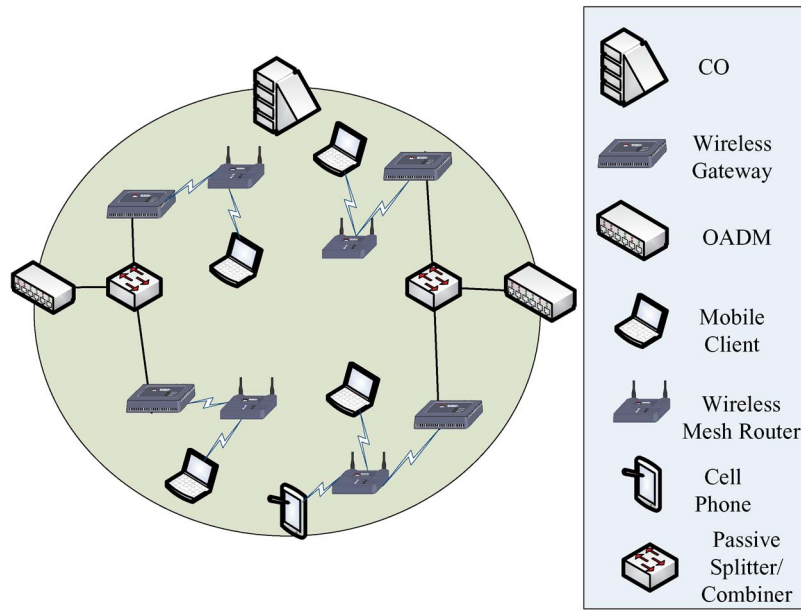

Fig. 22. WDM-PON integrated with WiFi mesh network.

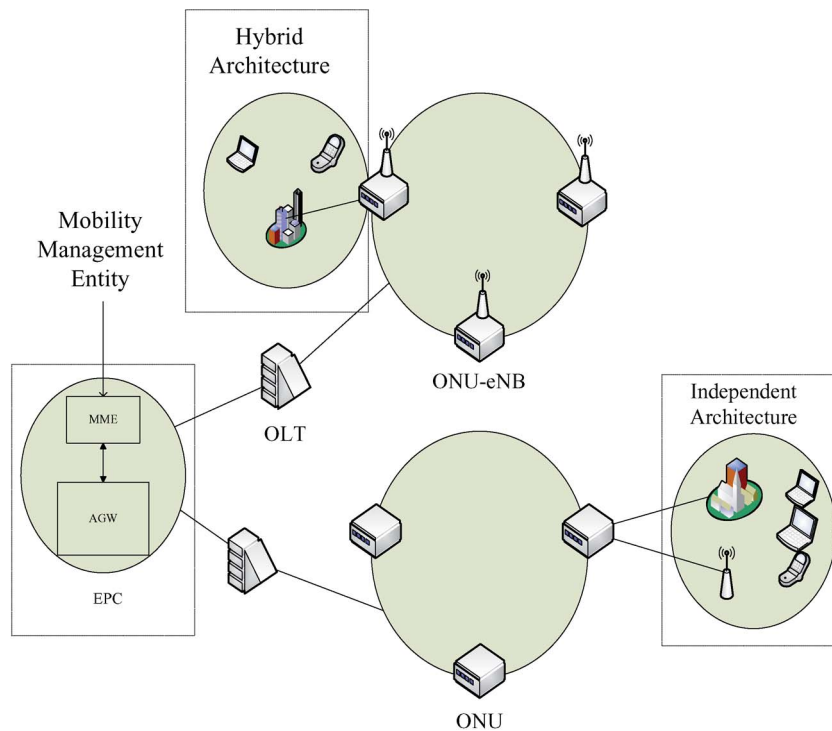

Fig. 23. A WDM-PON converged with a LTE RAN.

multiple of eNBs, which are associated with thousands of subscribers. The connection architecture of ONU and eNB can be associated with either the independent or the hybrid approach.

C. GPON Backhaul Network

A viable integrated network could also be implemented by the convergence of GPON as backhaul and WiMAX as front-end [64]. In this framework the QoS provisioning is applied by combining the T-CONTs with multiple service classes defined by the WiMAX standard.

D. Multi-Stage Backhaul Network

By exploiting the substantial benefits of both optical and wireless technologies, this category includes the possible extended combination of multiple technologies. A three level network is proposed in [69], as drawn in Fig. 24. The first level constitutes a WDM-EPON, as proposed in [70], where the OLT is able to schedule transmissions using any available wavelength channel. A number of wavelengths is shared by the OLT and the ONUs via an AWG device. Hence, the multiplexing of a large number of wavelengths into a single optical fiber is

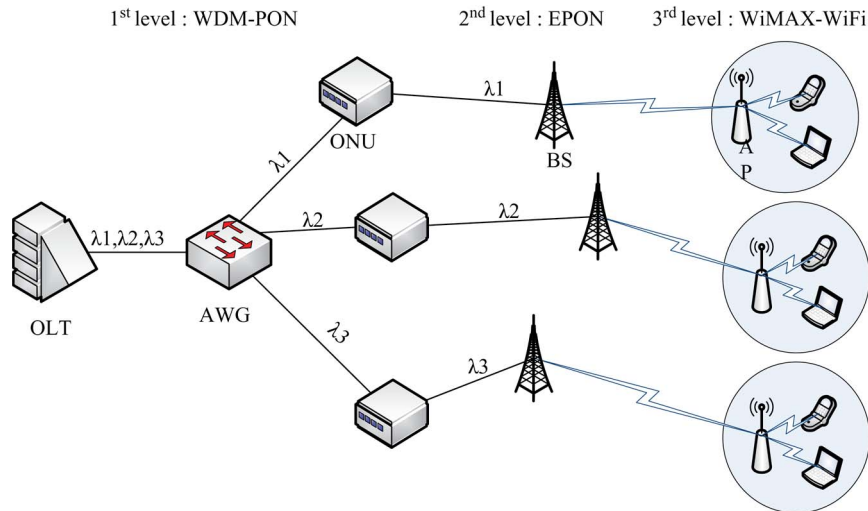

Fig. 24. Three-level network combining WDM-PON, EPON, WiMAX, and WiFi.

feasible, increasing though, the transmission capacity of the enabled optical networks. At the second level, an EPON is used to connect the ONUs and the WiMAX BSs, as it is considered the most appropriate optical technology to directly communicate with the WiMAX network. In the last level, the association between the WiMAX and the WiFi takes place.

Based on the same WDM/TDM multi-stage levels as in the [69], a hybrid wavelength division multiplexed/time division multiplexed PON is proposed in [71]. Since that the inter-ONU communication in a conventional PON is performed through the OLT, causing additional encumbrance on upstream and downstream traffic, the approach in [71] mainly aims at providing direct inter-ONU communication without the OLT engagement. Each ONU is further equipped with a tunable transmitter and a fixed receiver. Additionally, the ONUs are separated into groups, where a dedicated wavelength is devoted to each group to receive the inter-ONU traffic using the fixed receiver. Similarly, the tunable transmitter is used for sending inter-ONU traffic to other groups.

A highly innovative architecture that meets the requirements of both smart power distribution networks and power consumption reduction is depicted in Fig. 25. The network in [22] involves optical and wireless sensor technologies, plug-in electric vehicles (PEVs) [72], [73], and distributed energy recourses such as solar panels. An optical ring-star network connects the power grid's distribution management system (DMS) with the EPON and the WiMAX networks. Subscribers are able to be connected either to a WiMAX BS or to an EPON OLT through the ONUs. Considering wireless technologies beyond the WiMAX, WLAN neighborhood area network (NAN) with mesh topology based on IEEE 802.11s takes place at the proposed FiWi network. The NAN consists of a) the mesh portal point (MPP) node which is placed at the ONU interface (gateway) to the NAN, b) the mesh access points (MAPs) which are associated with the subscribers and offers them access to the NAN, and c) the mesh points (MPs) which essentially plays the role of the router, since it relay the traffic between the MPPs and the MAPs. Furthermore, fiber optic sensors and wireless sensors are placed across the optical fiber and the wireless net-

works (WiMAX and NAN) respectively. Both optical and wireless sensors remotely communicate with the DMS using dedicated channels.

A combination of NG-PON with a gigabit-class WLAN-based mesh network forms an integrated long-reach and cost-effective network [74]. Fig. 26 shows the wavelength-routing multi-stage WDM-PON adopted in the network backhaul. An AWG is used to route each of the Λ wavelength to a different distribution fiber which contains one or more stages. Each stage includes a wavelength-broadcasting splitter/combiner and each wavelength is used for serving a different sector.

Finally, a promising architecture that adopts the IEEE 802.17 resilient packet ring (RPR) platform is proposed in [75]. RPR connects a number of WDM-extended-EPONs [70] which, in turn, are connected with WiFi-based mesh networks. Each WDM-EPON network uses a tree topology, in which the root consists of the corresponding OLT. Some of the RPR nodes employ wireless-optical interfaces permitting connection with front-end WiMAX networks.

E. Discussion and Remarks

A comprehensive comparison regarding the representative converged enabled technologies presented is provided. Significant issues including a) equipment cost, b) implementation complexity, c) network coverage, d) application protocol, e) scalability, and f) survivability are examined. Table IV summarizes the comparison issues. The first two columns contain a number of up-to-day representative proposed FiWi networks, as classified in this Section. The implementation cost is affected by the number of the used equipment. The complexity magnitude depends on the simplicity of the adopted equipment. A WDM-PON network seems to be an expensive selection compared to TDM-PON (EPON and GPON) solution since it engages additional components such as multiplexers/demultiplexers. A TDM-PON integrated with a WiMAX network is a relative affordable solution supporting demanding applications using the wide-used Ethernet protocol. However, since the TDM PON allocates the whole bandwidth in time division manner,

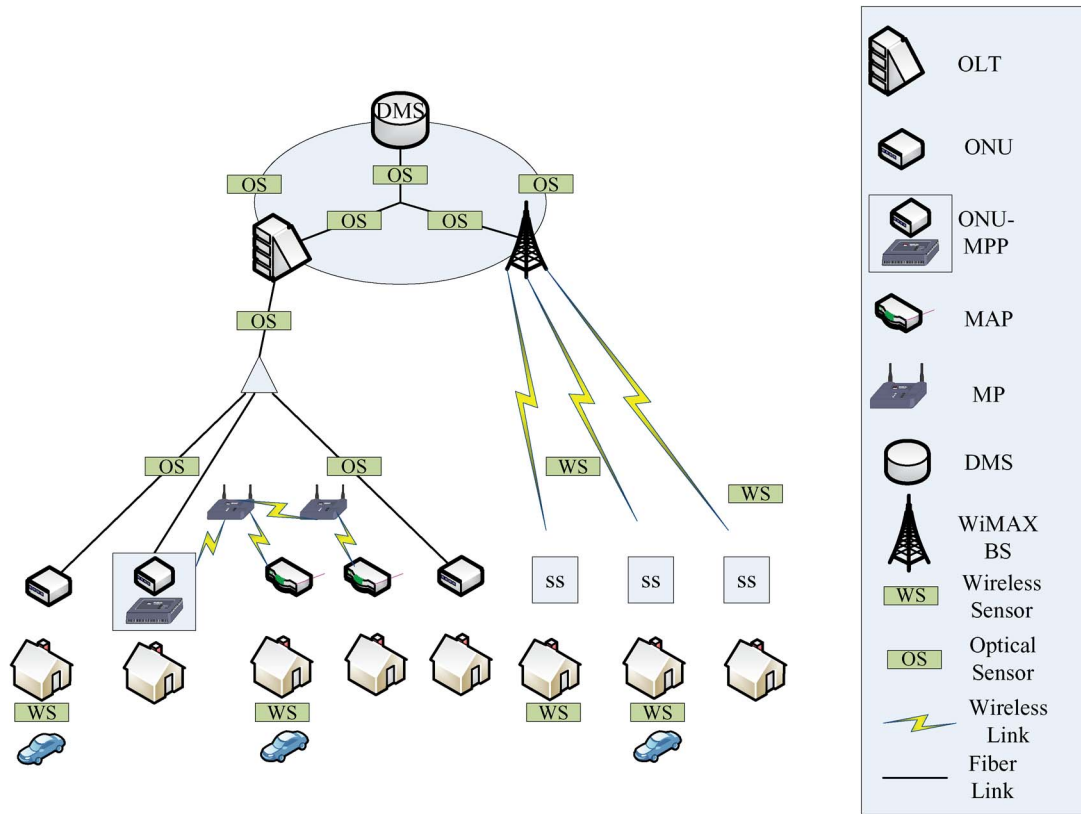

Fig. 25. Multi-stage, smart power distribution WiFi network architecture.

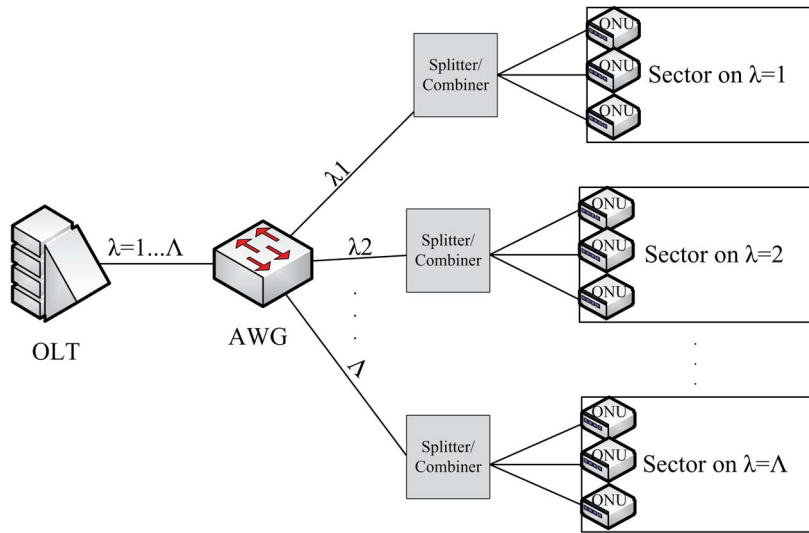

Fig. 26. Wavelength-routing multi-stage WDM PON.

the number of supporting ONUs, and therefore the number of users, are limited, resulting in low scalability. It is worth noting that the EPON/WiMAX (OOW) exhibits adequate network coverage, scalability and protection by inserting intermediate networks, nevertheless, at expense of high cost and considerable implementation complexity. Given that the wireless mesh mode network is a simple, fault-tolerant, cost-effective, and scalable implementation due to its self-organizing capability, the WOBAN solution exploiting the benefits of both TDM-(E)PON and WiFi-based mesh technologies sounds like a re-

liable and robust selection. Instead of TDM-PON, the WDM-PON technology is scalable due to its capability of serving ONUs by supporting multiple wavelengths over the same fibre. Furthermore, the scalability, the network coverage and the supported services are considerably enhanced when integrating with LTE network. Considering the multi-stage networks, the high implementation complexity and cost constitute negative parameters for potential deployment.

An interesting question is whether LTE is capable of cooperating with the various architectures mentioned in the previous

TABLE IV
CLASSIFICATION OF CONVERGED ENABLED TECHNOLOGIES

| Optical Domain | Wireless Domain | Equipment cost | Implementation complexity | Network Coverage | Application Protocol | Scalability | Survivability | | |
|------------------------------|--------------------------------------|----------------|-----------------------------|------------------|----------------------|-------------|---------------|------|--------|
| EPON Backhaul Network | WiMAX [55] | Medium | Medium | Medium | Ethernet | Low | Medium | | |
| | WiMAX (OOW) [60] | High | High | High | Ethernet | High | High | | |
| | LTE [67] | Medium | Medium | Medium | Ethernet | High | Medium | | |
| | WiMAX or WiFi mesh mode (WOBAN) [51] | Low | Low | High | Ethernet | Medium | High | | |
| WDM PON Backhaul Network | WiFi mesh mode [52] | Medium | Medium | High | Various | High | High | | |
| | LTE [67, 68] | Medium | Medium | Medium | Various | High | Medium | | |
| GPON Backhaul Network | WiMAX [64] | Medium | Medium | Medium | Ethernet | Low | Medium | | |
| Multi-stage Backhaul Network | WDM-PON | TDM-PON | WiMAX/WiFi [69] | High | High | High | Ethernet | High | Medium |
| | WDM-PON | TDM-PON | WiFi mesh mode [71] | High | High | High | Ethernet | High | High |
| | Smart-Grid /EPON | | WiFi mesh mode/WiMAX [22] | Medium | High | High | Ethernet | High | High |
| | NG-WDM-PON | NG-WDM-PON | WiFi mesh mode [74] | Medium | Medium | High | Ethernet | High | Medium |
| | RPR | WDM-PON | WiFi mesh mode / WiMAX [75] | High | High | High | Ethernet | High | Medium |

Section. Since the LTE technology has emerged as a compelling wireless backhaul for high-potential converged access network, the architecture selection to integrate the optical and the LTE domain is of paramount importance. Due to the implementation simplicity of independent architecture, the PON and the LTE systems can be simply operated independently. Fig. 23 illustrates an integration of WDM-PON and LTE. In this network paradigm, the ONU and the eNodeB can be interconnected since they both support a common interface considering the eNB as a common user associated to the ONU. Regarding the hybrid and combined architecture, the ONU and the eNodeB can be considered as a single box, as shown in Fig. 23. This integration can be realized both of software and hardware operations. For example, in [68] this integration comes into play by interconnecting the ONU and the eNodeB. In particular, this integration utilizes three function modules: a) ONU module, acting as interface to PON section, b) LTE-eNodeB, including the eNodeB packet classifier and the LTE upstream scheduler, and c) the common control module, playing the role of the ONU-eNodeB coordinator. The work in [67] is

applied the hybrid architecture consolidating the ONU with the EPC to implement a LTE—EPON network. The combined architecture can be also adopted by placing a joint controller between the ONU and the eNodeB offering transparent integration without the involvement of other network operators resulting in increasing the cost even more. The role of the joint controller is twofold, a) being in charge of sharing status information among ONU and eNodeB b) managing the integrated traffic. Even though the literature does not provide any unified, MoF and software-based architectures involving LTE technology, such integrations are possible to be realized. For instance, a unified architecture could be feasible by encapsulating Ethernet frames within LTE data units. Similarly, MoF concept could realized combining LTE and PON architectures by modulating LTE signals onto optical fibre (like in the case of WiMAX). Lastly, the LTE architecture may employ SDN-based bridges, by taking advantage of the standardized software—based architecture, similar to Fig. 18(a), aiming at establishing logical connections between the ONU and the eNodeB.

VII. CLASSIFICATION OF DBA SCHEMES

This Section is dedicated to provide insights into DBA schemes, algorithms, and frameworks designed and implemented for hybrid wireless-optical access networks. Initially, the main building blocks of common DBA schemes are presented. Then, the most significant criteria leading to DBA classification are enlightened. Lastly, the DBA schemes presented in the literature are listed and compiled based on those criteria.

A. Definitions

In conventional PON systems, DBA is defined as the process of providing statistical multiplexing among ONUs [76]. In the case of hybrid wireless-optical access networks, the provided statistical multiplexing is also expanded to the wireless part of the network, i.e., the SSs. Hence, the aim of the DBA is to provide bandwidth distribution via statistical multiplexing to the users connected by either optical or wireless interface. The performance of the hybrid wireless-optical access networks seriously depends on the DBA efficiency. This is due to the following reasons:

- The data traffic on the individual links in the hybrid network is quite bursty, in contrast to metropolitan or wide area networks where the traffic generated is relatively smooth due to the aggregation of many sources [76].
- Diverse user profiles, as aggregated by both optical and wireless domains, generate volatile, and therefore, unpredictable traffic patterns. Fixed scheduling techniques and static bandwidth allocations are insufficient to cope with contemporary services and applications. To this end, they suffer from network performance degradation and QoS disorientation.
- The large geographical region covered by both optical and wireless domains extends the potential user population; at the same time, it imposes high geographical diversity. The distance variance is quite high in both network domains. Given that a standalone PON may cover 20–50 Km with optical fiber, while a typical WiMAX network may provide connectivity in 50–70 Km, it is expected that distances between users connected to the same point, e.g., ONU, could be extremely variant. In the light of the aforementioned aspects, variant, and even high, propagation delays reveal the need for a dynamic, efficient, and effective bandwidth distribution scheme.
- Inevitably, a hybrid wireless-optical network, deployed in an urban or high-populated area, could face congestion problems. The role of the DBA is crucial towards resolving congestion issues, providing AC, and ensuring QoS contracts.

In the following, we call the ONU that is enhanced with a wireless BS as *enhanced ONU* unless explicitly stated differently. Also, any IEEE 802.16 wireless standard enabled is simply stated as WiMAX. The tree topology is considered as the typical PON topology considered in this Section, unless explicitly stated differently, e.g., ring or RPR. Moreover, the optical network part is often called optical domain while the wireless region is called wireless domain.

B. Building Blocks

The majority of the DBA schemes consists of three main building blocks: a) the *QoS mapping block (QoSMB)*, b) the *QoS provisioning block (QoSPB)*, and c) the *scheduling block (SB)*. Normally, the order of performing the aforementioned tasks is as follows. First, the QoSMB is responsible for addressing the QoS diversity problem of the different enabled technologies in the hybrid network. Accordingly, it stores the data coming from the optical domain towards the wireless BS buffers (downlink) and vice versa (uplink). Second, the QoSPB is triggered to decide whether an arriving data packet (connection request) is accommodated (accepted) or dropped (rejected) based on single or multiple criteria, for example the agreed QoS contracts. Third, the SB governs the way of forwarding data packets or/and data flows from the optical to the wireless domain and vice versa. This study classifies the related research efforts based on the order previously listed, since the following order is applied during the DBA process.

C. Operation

The QoSMB is responsible for accomplishing three tasks: a) it compounds the different service classes of the integrated network, b) it integrates the service queues in both optical and wireless section, and c) it applies priorities to each converged queue. First, it decides on how the common services and application are supported in terms of service classes. For example, a common practice is to merge EPON and WiMAX QoS service classes to three common types, namely the UGS/EF, the rtPS/AF, and the BE/BE. In this way, the optical QoS class types remain intact and the WiMAX traffic classes are merged, e.g., the nrtPS and the BE type are merged to the unified BE traffic class, while the rtPS and the ertPS are combined to the rtPS class. Second, it ensures that all components either in optical or wireless domain use the same service queues. Hence, assuming the aforementioned practice, a voice traffic stream is stored to the UGS/EF service queue in both enhanced ONU and SS. In addition, the OLT makes use of the UGS/EF queue identification to broadcast voice data to SS in the downstream direction. Third, the QoSMB should define different priorities for each queue. This task is crucial, since it considerably affects the DBA performance. Obviously, in the case of having the UGS/EF, the rtPS/AF, and the BE/BE classes, the highest priority should be granted to the UGS/EF class and the lowest priority to the BE/BE class. Otherwise, BE traffic streams are favored over the critical voice (or video) data packets and QoS disorientation phenomena occur. In terms of efficiency, meaning the ability to meet service requirements, blocks that merge several priority queues may suffer from high delays, since two or more queues share the same priority value while handle data packets of different sensitivity.

The QoSPB involves three operations: a) incoming traffic aggregation, b) serving traffic requests, and c) AC execution. Each incoming data packet is compiled and stored into the corresponding service class. For each service class a FIFO policy is applied. Hence, for two voice packets that are stored in the same priority queue the one having the least arrival time

is favored. Nevertheless, the FIFO policy is employed for each logical queue with the same priority value. The way of selecting data packets for transmission (or forwarding) between queues with different priorities is the second task of QoSPB. The way of serving traffic requests is maybe the most critical duty of the QoSPB. Various techniques have been proposed in this direction. For example, the *strict policy* serves the priority queues one by one starting from the queue with the largest priority value and ending to the queue with the lesser one. Nonetheless, resource starvation effects are attached to this technique since newer high priority data packets preempt the still waiting transmission low priority traffic streams. Other methods adopt minimum guaranteed bandwidth for each priority class resulting in better results. Lastly, an important, yet optional, feature that the QoSPB entails is the AC execution. For each incoming traffic stream, the QoSPB decides on whether this stream is admitted or dropped, utilizing a set of rules which compose the applied AC. The rationale behind this is associated with uninterrupted QoS provisioning. In particular, the role of AC is to prevent QoS disorientation by not admitting a new incoming traffic session when the needed resources to meet its requirements are not (currently) available. In this way, it secures the traffic streams that are already carried out. Many AC schemes are structured in a distributed manner, applying admission duties in both optical and wireless domain. The operation of a robust AC is deemed crucial in environments where multiple users, distinguished by different SLAs, contend for access.

SB constitutes the focal process of the DBA framework. It is responsible for effectively delivering traffic streams across the hybrid network. Since no collisions are allowed in the PON backhaul, a polling strategy is mandatory. Typically, the OLT, as the main decision making entity, applies a polling mechanism and the coordination between the OLT and the various network entities, taking place in the polling process, is achieved via control packets and messages. The polling application is critical; thus it determines the main criterion of distinguishing the state-of-the-art scheduling techniques as described later in this Section. For example, by using the IEEE 802.3ah MPCP mechanism in EPON backhaul [29] the designed DBA algorithm is compliant with the standard. In addition, SB is responsible for performing bandwidth allocation. This task includes bandwidth distribution among SSs (or even among SSs and users connected to ONUs via optical interface). Therefore, a bandwidth allocation policy holds, defining how the available resources are shared in dynamic fashion. For instance, by re-distributing the surplus bandwidth of under-loaded users (or even priority queues) to the over-loaded ones the DBA framework becomes more efficient and fair than static or traffic-unaware policies. Furthermore, seeking optimization is an intriguing undertaking in the context of DBA developing. One of the most popular optimization techniques is the traffic prediction application. In particular, estimation methods are developed to calculate the estimated bandwidth demands during the control information exchanging. Note that this period may present notable delays due to large propagation time in hybrid networks. Prediction techniques, acting as an enhanced component of the polling mechanism, attempt to advance the network performance by reducing the experienced delay in delivering data. Even though

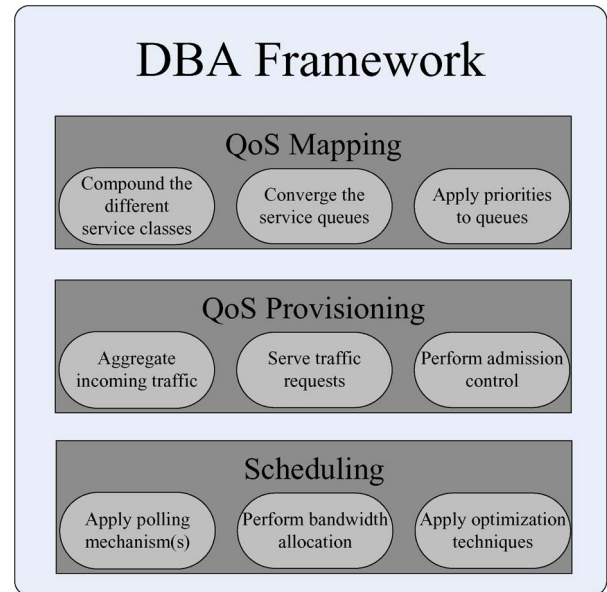

Fig. 27. The structure of DBA framework subject to the QoS blocks.

prediction techniques constitute powerful tools, the expected impact on performing traffic prediction is questionable, since the generated traffic in access networks is quite bursty and in some cases unpredictable.

Fig. 27 illustrates the structure of DBA framework subject to the QoS blocks.

D. QoS Mapping Block

QoSMB resolves QoS diversity issues in the hybrid network. Each technology, either optical or wireless, manages the QoS provisioning in a different way. For example, the convergence of Ethernet PON and WiMAX access networks should regulate the differentiation regarding the service classes, i.e., the EPON services are commonly divided into three main service priorities, while the WiMAX standard defines five service classes. Bearing in mind that a bandwidth allocation policy is dramatically affected by the service priorities, it is clear that the convergence of different QoS classes is a critical issue.

Optical-Based: The most popular way to converge the traffic QoS differentiation in hybrid wireless-optical networks is by adopting the standardized QoS support in PONs. This is attached to the fact that traffic streams, coming from the wireless part, have to traverse through the hybrid ONU and therefore to be even temporarily accommodated in the hybrid ONU buffers.

We relate on the *Triple Priority* category when an EPON is adopted. This refers to the case when the three priority classes of the EPON are adopted as the main QoS differentiation service classes of the whole hybrid wireless-optical network and the priorities of the enabled wireless standard are accordingly adapted to the three priorities of the PON platform. The work in [63] introduced converged EPON and WiMAX QoS specifications by defining common service types for the hybrid wireless-optical network. In particular, the applied QoSMP defines only three common service types, namely the UGS/EF, the rtPS/AF, and the BE/BE priority classes, where the first

notion corresponds to the wireless QoS type and the second to the optical one. This classification leaves the optical QoS types untouched, however the WiMAX traffic classes are merged as follows; the nrtPS and the BE types are merged to the unified BE traffic class, while the rtPS and the ertPS are combined to the rtPS class. In this way, three common traffic classes handle the logical priority queues in the whole network.

An analogous classification appears in [77]. The proposed QoSMP mechanism defines three traffic classes, i.e., EF, AF, and BE, where the UGS class is associated with the EF class, the rtPS and ertPS classes are merged to the AF class, and the BE class gathers the remaining nrtPS and BE classes of the IEEE 802.16 standard.

Another approach employing the triple priority method appears in [59], [78]. Three classes are defined, EF, AF, and BE, without, however, providing the way of converging wireless and optical classes together.

When EPON is combined with LTE an interesting feature is identified. Given that a) the EPON framework is capable of supporting up to eight traffic classes, implemented in eight queues and b) the LTE defines eight standardized QCI that classify data traffic into eight different classes of service, the QoS mapping of the above technologies seems a straightforward task, where the *8-Queue* category is defined [68]. In particular, eight differentiated priority queue are used to handle the different EPON traffic QoS classes and this taxonomy is also followed by the wireless QoS management. However, due to the different nature of handling the QoS guarantees, the QoS mapping should be carefully designed [68]. The work in [79] investigates the QoS mapping concept by proposing and evaluating two possible schemes on converging the QoS provisioning in PON-LTE hybrid networks. The first scheme, which is referred to as 1:1 mapping, and is also proposed in [68], aligns one by one the queues of the PON with the eight QCIs of the LTE, assuming that eight service classes are employed, as using in an EPON framework. An alternative approach is proposed in [79], which introduces the group mapping method. To this end, assuming that the number of the QoS service classes in the PON domain is lesser, the different QoS specifications are aligned as follows. The three main service classes in the PON, that is high priority, e.g., EF, middle priority, e.g., AF, and low priority, e.g., BE, are attached to QCIs. Thus, a single QCI is attached to the high priority class, three QCIs are attached to the middle priority class, and the rest three QCIs are attached to the low priority class. This type of categorization falls in the triple priority category. In addition to 1:1 mapping, the work in [79] presents evaluation results that indicate a) the 1:1 QoS mapping induces decreased packet delay compared to non-mapping regarding the high priority bearer (carrier of QCI 5) and middle priority bearer (QCI 6) display and b) the group mapping causes performance degradation of the middle priority group (QCI 1, 2, and 3) compared to the 1:1 QoS mapping technique.

By adopting a GPON architecture, the *CONT-based* category is defined. It implies the usage of GPON in the optical domain. The work in [64] presented a compelling testbed incorporating a combination of GPON and WiMAX systems. Four T-CONTs are utilized to be aligned with the five traffic classes used in WiMAX. Specifically, in the ONU side the five traffic classes

are mapped into the four T-CONTs as follows: The UGS is aligned with the first T-CONT. ErtPS and rtPS are merged into the second T-CONT. NrtPS is coincided with the third T-CONT and BE is attached to the fourth T-CONT.

Wireless-Based: The *Wireless-based* branch is quite rare, as it corresponds to PON-wireless paradigms where the OLT entirely governs the DBA process. Considering that the OLT directly communicates with the SSs to meet their bandwidth requirements, the QoS mapping follows the QoS traffic classes as defined in the SSs. As the work in [61] incorporates, the five well-known classes of the WiMAX standard are utilized in the whole hybrid network. Hence, the QoS mapping in hybrid ONU simply adopts the priority queues of WiMAX. Possible drawbacks of using this method are the adversity of combining local traffic, generated by users attached to the optical interfaces of the hybrid ONU with traffic requests coming from the SSs.

A similar technique is also applied in [80]. An EPON-WiMAX architecture is suggested, where a total of five queues for UGS, rtPS, nrtPS, ertPS, and BE classes of service are considered in both SSs and the enhanced ONU. However, the classification method of associating the EPON service classes with the above five queues is not explained in detail. Moreover, this mapping policy is slightly differentiated in the optical domain. In particular, the BE service class is further divided into four sub-classes, known as BE VPN service classes. In this way, each ONU-BS uses eight service classes in total; four of them are dedicated to the UGS, rtPS, ertPS, and nrtPS queues flows, and the remaining four to the rest four BE VPN bandwidth needs.

The authors in [81] proposed an EPON-WiMAX architecture formed in a ring topology. Five service types are defined according to the IEEE 802.16 standard for all network planes. Considering that the RPR standard entails its own traffic classes, there is a need for association between the service types of the EPON-WiMAX and the ring. In this way, the authors proposed a possible mapping which associates the service types UGS, ertPS, rtPS, nrtPS, and BE to classes A0, A1, B-CIR, B-EIR, and C of the RPR, respectively. As in the RPR standard, class A traffic has priority over class B traffic which has priority over class C traffic. Therefore, the OLT schedules these traffic classes in the order A0, A1, B-CIR, B-EIR, and C.

The work in [82] assumes that the enhanced ONU adopts the five WiMAX classes in a one-to-one basis; hence the QoS mapping in the optical part utilized five of the (possible) eight priority queues. The same policy is applied in [83].

Modified: Beyond the aforementioned categories, custom methods of functioning QoSMB could be found in the literature. We call this type as *Modified*. For example, the authors in [60] proposed a modified QoSMB, where each ONU handles eight priority queues. Those are listed below from the highest to the lowest priority: The first one remains the UGS having highest priority. The ertPS queue treats the actual bandwidth requests of ertPS connections. Beyond the rtPS queue, data packets of rtPS connections featuring a deadline time in the forthcoming cycle are managed by the rtPS-s-dead queue. Next, rtPS-l-dead queue stores rtPS connections having later deadline time. NrtPS queue handles nrtPS connections, while an

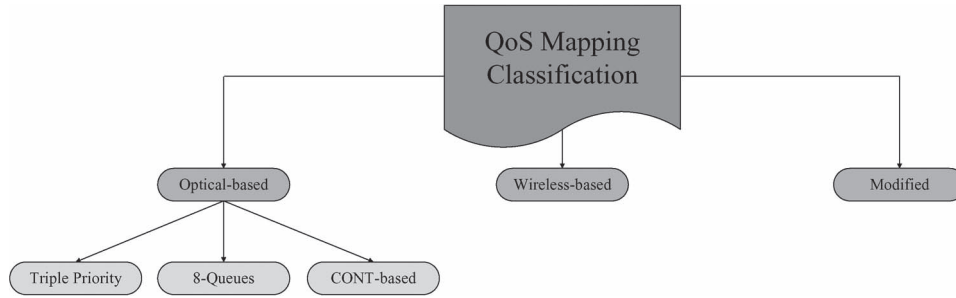

Fig. 28. QoS mapping classification.

assessment queue holds temporary connections under monitoring by the AC policy. Finally, the lowest priority is attached to the BE queue handling BE connections. At the same time, the QoSMB component at the hybrid ONU, defines five (typical) service types in the wireless domain, i.e., UGS, ertPS, rTPS, nrtPS, and BE.

The modified technique of [84] defines a new IEEE 802.16 service class to handle mission critical systems such as healthcare, police, and firefighting. To achieve this, a new IEEE 802.16 service class is defined, called as emergency grant service (EGS). To provide stringent QoS requirements, the EGS class has the highest priority compared to the conventional IEEE 802.16 classes. In essence, it uses a separate buffer in both enhanced ONU and Ss, handling emergency messages in a direct fashion. In the optical domain the usage of six queues is adopted, i.e., the five conventional service classes of the WiMAX plus the new EGS category.

The inter-channel and the intra-channel Dynamic wavelength/Bandwidth allocation (IIDWBA) algorithm is inaugurated in [85]. The rationale behind IIDWBA is quite compelling; it provides a wavelength allocation strategy which comes in place when multiple channels are available in the hybrid network. The applied QoS mapping technique is not adequately specified, rather the authors leave open the implemented architecture in the wireless part of the network. However, the specific algorithm could fall in the modified category, since the authors imply that the considered network traffic belongs to the BE service class.

Discussion and Remarks: Undoubtedly, the QoS mapping module constitutes a critical feature towards the wireless-optical integration. The traffic class priorities categorization based on PON standard service types seems to prevail, because the traffic streams coming from the wireless domain towards the backbone are inevitably passed through the optical domain, which means that temporary buffering is mandatory. Nonetheless, this form of mapping could be beneficial when local traffic is present in the optical interfaces of the hybrid ONU. Thus, traffic streams from both wireless and optical interfaces could be easily multiplexed into common data streams towards to the OLT. On the other hand, using a modified mechanism to provide converged QoS traffic classes may violate the standards required to facilitate the implementation of final prototypes and commercial products.

Fig. 28 displays the classification of the multiple categories regarding the integrated QoS mapping strategies.

E. QoS Provisioning Block

In modern, hybrid wireless-optical networks the QoS provisioning is not only necessary, but it might be the key factor of discriminating the hybrid paradigm over conventional existing access technologies such as xDSL or satellite. The QoS provisioning mechanism, which is typically located at the enhanced ONU, governs the way of providing QoS guarantees to both wireless and optical interfaced users. In the following, we classify the QoSPB mechanisms applied in hybrid wireless-optical networks in three main categories: a) *strict policy*, b) *minimum best effort*, and c) *admission control*.

Strict Policy: The simplest way to facilitate QoS is to provide differentiation of traffic and different service to each differentiated traffic class [76]. Typically, the assignments of a hybrid ONU include a) classification of service types, b) data traffic buffering, and c) function of a strict priority policy between the service classes. An indicative example of applying strict policy can be found in [61]. In particular, connection requests coming from a variety of applications in Ss arrive at the hybrid ONU, where they are aggregated and categorized from UGS to BE in accordance with the typical five WiMAX priority classes. Next, the aggregated five service class requests are served one-by-one in a strict priority manner, from UGS to BE. This method is referred as *standard strict priority scheduling*.

Nevertheless, this method induces a phenomenon known as the *light load penalty* [86], [87]. This occurs when high priority data packet arrive at full buffers and preempt the bandwidth reserved for low priority data packets. As a result, low priority data connections experience resource starvation causing unfair bandwidth distribution.

A potential solution is proposed in [87], where a secondary buffer is employed so as to maintain the reporting status at the time of sending the request and transmit the stored data according to the reporting status at the next grant. High priority data packets may arrive at the primary buffer without affecting the process of the secondary buffer. This technique is called *two-stage DBA* and it is adopted by the works in [59], [77], [78]. Therein, an intra-ONU scheduling takes place in the hybrid ONU. Three classes are defined, namely EF, AF, and BE. The technique incorporates a two stage DBA working with a single (primary) buffer only. In the first stage, the reported requests of each class are served in accordance to their priority following a FIFO manner. Afterwards, in the second stage, the newly incoming data is served in accordance with the amount of the predicted bandwidth.

We denote the strict priority principle adopted in [60] as *mixed strict priority* policy. The DBA component in the hybrid ONU defines five (typical) service types in the wireless domain, i.e., UGS, ertPS, rtPS, nrtPS, and BE. The strict priority principle is obeyed having the following rules: a static bandwidth is allocated to UGS connections and the requested bandwidth is granted to ertPS traffic demands. The *earliest deadline first (EDF)* service discipline is applied to rtPS traffic, according to which data packets having earliest deadline are favored. The nrtPS traffic demands are served by the *weight fair queue (WFQ)* service discipline, where weights per connection indicate their priority. Lastly, the remaining bandwidth is equally granted to each BE request. Although, the applied principles are wide-used and well-known, no details are provided about the above QoS-enabled features, e.g., the determination of the weights.

Similarly, mixed strict priority is also introduced in [57]. As mentioned before this work defines three traffic class priorities according to the PON QoS requirements, i.e., EF, AF, and BE. Highest priority is given to EF class, and the rest requests are served after. The rest priorities are dynamically configured, following the strict priority policy.

Minimum Best Effort Policy: Instead of proposing an enhanced AC, the authors in [63] introduced the *minimum best effort (MBE) policy*. The motivation behind MBE is quite simple; all service types are given a minimum bandwidth. In this way, it is argued that a fair bandwidth distribution is achieved and the connection drop ratio could be low. In particular, a fixed amount of bandwidth is given to each of the SS in a static manner to meet the bandwidth needs stemming from UGS/EF requests having the highest priority. Next, the rtPS/AF bandwidth requests are treated by applying a dynamic allocation based on the QoS and the traffic arrival rates, as discussed later in this Section. Lastly, a minimum bandwidth portion is given to each SS to cover the BE/BE needs to avoid service starvation of the lowest priority service class.

Even though the authors in [85] do not distinguish QoS-based traffic classes, the proposed IIDWBA algorithm falls within this category. This is attached to the fact that the algorithm ensures a minimum guaranteed bandwidth. The excess bandwidth is fairly shared among the wireless clients.

Admission Control Policy: The AC is one of the most crucial mechanisms to provide an effective and fair network services to end users, while it poses as an alternative technique to support and protect QoS requirements in access networks. It governs the admission of requested data flows or connections oriented from end users. It decides either to accept the data delivery request, and therefore, it utilizes a buffer memory in a priority queue to store the incoming data packets, or to reject the request, and in turn, the incoming data packets are dropped. Undoubtedly, an efficient AC ensures fairness since the QoS contacts are respected and the users are equally treated by controlling their acceptance ratio of incoming connection requests. The concept of applying an AC to decide whether a connection is admitted or dropped has been well investigated in PONs [88], [89]. However, the field of hybrid wireless-optical is differentiated since a hybrid ONU accepts connections from remote sources like SSs. Normally, the AC module is embedded in the BS,

where the incoming requests from the SSs are monitored and controlled. Nonetheless, the AC policy could be operated either at each SS or at hybrid ONU. The suggested AC policy in [90] is called *integrated optical wireless admission control (IOW-AC)* and runs at the ONUs. Upon a SS connection request is applied, the ONU is able to estimate the waiting time of the related connection based on cycle length provided by the GATE message. Hence, QoS requirements of the incoming connections are examined in accordance to the estimated delay and the ONU decides whether to accept serving them.

The *distributed admission control (DAC)* policy is introduced in [81]. The authors proposed a RPR-EPON-WiMAX architecture, having a ring topology, where each EPON segment is connected to the ring via two OLTs. This architecture employs two connections between each EPON segment with the ring at the expense of extra installation cost and QoS degradation in the case of a failure. Hence, the connectivity of each SS involves a primary and a secondary OLT. The DAC is structured in two levels; initially, a decision is reached in the WiMAX BS side, where a candidate data stream may experience the following states: it may be a) rejected, b) initially accepted, and c) temporarily buffered. Then, the final decision regarding the admission of those streaming that either initially accepted or temporarily buffered is made by one of the OLTs. In the WiMAX BS a candidate data stream is rejected if its requirements cannot be met by the wireless interface. For example, if the WiMAX BS is unable to support the requested mean data rate of a rtPS stream it directly rejects it. On the other hand, the decision on whether a candidate stream is initially accepted or buffered depends on the backhaul data rate. The backhaul data rate stems from the RPR capacity, i.e., the supported bandwidth of the installed ring. Thus, the WiMAX BS initially accepts a candidate data stream if all QoS requirements are met from both wireless and backhaul interfaces. However this admission is not permanent. The accepted stream is monitored for a specific period of time. The WiMAX BS keeps the right to discard the monitored stream if no bandwidth resources are yet available. The admission of those streams that remain waiting is determined by the AC module running at the OLTs. The OLT AC operates in a twofold way whether a failure in the OLTs or their connections exists. The OLT that supervises the candidate stream is called host-OLT. Each buffered stream may remain under waiting status until either the required resources are guaranteed or the waiting time threshold in accordance to the setup configuration is violated and therefore the stream is rejected. The stream reservation is even allowed under failure incidence, thus a stream may be buffered in expectation of recovery. A waiting stream may be served from both OLTs. If neither OLT is able to afford the required resources a waiting stream is still discarded, even though each host-OLT is expected to advertise, and if successfully found to receive, extra bandwidth resources. Finally, data streams that are under supervision by their host-OLTs are decisively accepted to finalize their data delivery after a testing period of time.

A three-stage AC mechanism was proposed in [80]. Three components compose the distributed AC mechanism, where the first one is applied to the SS side, the second one to the ONU-BS interface and the third one to the OLT. The mechanism is

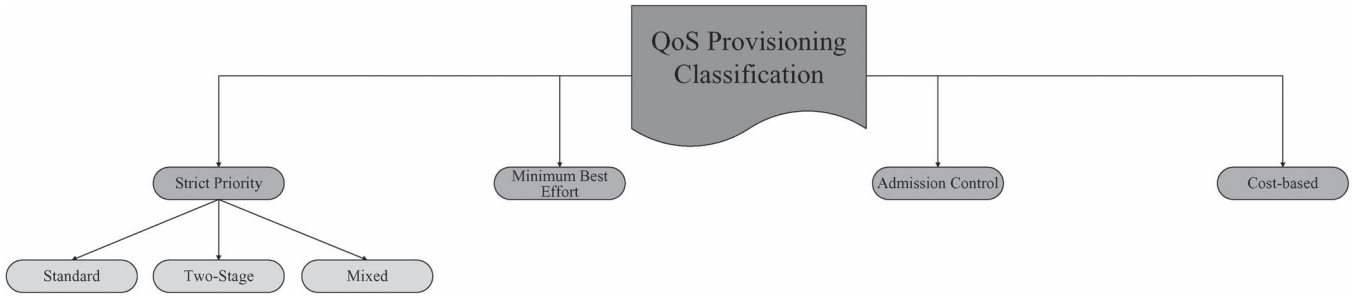

Fig. 29. QoS provisioning classification.

applied to real-time flows while the BE requests are permanently admitted. Each new flow receives network resources if the PHY rate of the corresponding SS is able to support its guaranteed bandwidth in accordance with the ongoing traffic conditions. In the next level, between the SS and the ONU-BS, the temporarily accepted request is reported at the ONU-BS. Once more, the ONU-BS applies local admission control and decides whether the request is further admitted based on the overall wireless bandwidth availability existing traffic. The flow is reported to the OLT if sufficient bandwidth resources are present. The final admission is successful if sufficient bandwidth resources in the optical domain are found. An updated version of the previous three-stage AC is developed in [82]. The subtle difference lies in how the reservation is made. In the earlier version [80] the reservation is fixed, while in the newer one [82] the AC mechanism applies a statistical multiplexing between the involved services which are called service bundles.

Cost-Based Policy: An interesting QoS provisioning scheme is suggested in [64]. The bandwidth distribution takes place in accordance with the *lowest-cost-first-algorithm*. The term of cost is associated with the users' cost towards getting their requested data packets delivered utilizing various types of service classes. For instance, the usage of multiple QoS classes causes larger cost. The cost is modeled using a duplex function including the delivery method, formed as a traffic class, and the volume of the traffic delivered. In essence, the algorithm proposed in [64] employs a dynamic strategy of finding the delivery method with the lowest cost. The algorithm may fail to dictate an appropriate delivery method, resulting in abandoning the requested user traffic delivery request.

Clearly, the lowest-cost-first algorithm seems arbitrarily designed, since it depends on naive criteria such as the cost setting. However, the authors present conducted experiments to display the algorithm applicability. Therein, the volume of user traffic is measured in terms of megabit, so the cost of delivering 1 megabit traffic per service class was set to 5, 4, 3, 2, and 1 for UGS, ertPS, rtPS, nrtPS, and BE respectively. The obtained results, among other metrics, display the channel utilization on delivering video-on-demand. According to the provided results the performance is deemed satisfied.

In [83] the requests of the first two priority classes are exhausted and the BE bandwidth requirements are examined. Afterwards, the proposed DBA calculates the surplus bandwidth and applies a cost-based function to distribute it to the remaining traffic classes. The cost function takes into account the

queue length of each class and a custom-defined weighting factor.

Discussion and Remarks: To avoid incorporating content periods between the SSs and the hybrid ONU, most works intend to devise novel, and often subjectively decided, QoS mapping schemes. Maybe the solution provided by [63] sounds the most promising, since a minimum BE bandwidth portion is ensured. However, the amount of traffic granted in hybrid wireless-optical networks experiencing heavy traffic conditions remains an open issue. Furthermore, the fairness issue is merely addressed. Most papers avoid measuring the fairness index, even though heterogeneous propagation delays may have crucial impact on resource allocation fairness [91], [92].

Fig. 29 illustrates the QoS provisioning taxonomy.

F. Scheduling Block

The core scheduling process is carried out by the SB. This module is responsible for providing the rules of effectively delivering data packets from one side to another within the hybrid network. Its effectiveness influences the performance of the whole network, since it controls crucial parts of the MAC layer such as control messages, packet field formats, transmission and delivery thresholds, and the way of interconnecting independent network components. In essence, the SB should be capable of providing timely data delivery, by maximizing the resource utilization, in a fair manner. By having a pervasive role, it entails a solid, rigorous, and effective design to adequately meet the demanding needs of modern applications and users.

The process of the SB should take into account the special features of the hybrid wireless-optical network. The optical domain is the core network because it provides the gateway to the backbone. Hence, the direction from the optical domain to the final users connected to the wireless part defines the *downlink flow*. On the other hand, the *uplink flow* is formed as the traffic goes towards to the backbone, i.e., the optical domain. Hence, the direction from the final users (in the wireless part of the network) to the optical domain is the uplink. Logically, the data delivery in the downlink direction is a straightforward task considering that the OLT is completely aware of the bandwidth needs of all users, whereas a dynamic scheduling scheme is required in the uplink direction. Many works refer to the bandwidth distribution as *uplink scheduler* or *uplink bandwidth distributor*. In the wireless part, and depending on the implemented technology, contention periods are allowed. However, the majority of the access mechanisms avoid employing contention

periods, because it is possible to cause QoS disorientation. To address this problem, various polling strategies are proposed, including the (MPCP) mechanism [29], which is maybe the most applicable policy adopted in the optical part of the hybrid network, as discussed in the following paragraphs.

Usually, the polling technique is applied in both domains to successfully deliver traffic to the edges of the hybrid network. The MPCP mechanism could be straightforwardly used to provide an efficient communication protocol between the OLT and the ONUs in the EPON part of the hybrid network. Many research efforts, nevertheless, manipulate the MPCP mechanism so as to facilitate the polling process. This action shed light to a notable trade-off; by using the MPCP intact a fully standardized procedure is kept. Otherwise, a more efficient polling technique is adopted at the expense of the standardization. Given that the telecom industry entails a high level of standardization to spend resources to an investment an open issue between efficiency and applicability appears.

Regarding the wireless part, the majority of the used technologies employ contention-free periods. This is attached to the fact that a contention access mechanism requires a complex and demanding bandwidth allocation strategy, while the polling strategy offers considerable merits such as collision-free periods, predictable duration, and controlled delay, which are crucial for sensitive services. While contention-based periods are allowed by the wireless standards involved in incorporating hybrid networks, it is a common strategy to avoid collisions and therefore provide a completely collision-free hybrid access network.

As far as the SB structure is considered, we can distinguish two main categories [91]: a) *independent* or *hierarchical scheduling* and b) *centralized scheduling*. It is worth mentioning that an extra category, namely *decentralized scheduling*, is considered in PONs delegating the entire DBA process to the ONU, however its applicability in hybrid wireless-optical networks is limited. The former case engages multiple decision components that are located at different places within the network. Normally, an intermediate entity, such the hybrid ONU, undertakes this task along with the OLT. Nonetheless, the scheduling decisions are made in common. The latter paradigm involves a standalone network entity capable of making efficient decisions affecting the whole network. Typically, this entity is the OLT that decides about both the optical and the wireless domains.

Independent or Hierarchical: Considering that the scheduling decisions are made in a distributed manner, both the OLT and hybrid ONUs are able to determine the way of distributing bandwidth. As previously mentioned, polling mechanisms are extensively used to acquire the bandwidth needs and, as a next step, grant decisions are made to meet the bandwidth needs assuring the applied QoS provisioning mechanism. Whether a prediction strategy is applied, either in the OLT or hybrid ONUs side, the independent scheduling can further divided into *prediction-sized* and *grant-sized* categories. The grant-based category includes DBA schemes that perform granting in absolute accordance with the reporting. In other words, an OLT or a hybrid ONU, obeying to grant-based policy, allocates as much bandwidth as requested, enclosed into the REPORT message

(if an EPON enabled). The prediction-based schemes apply a prediction mechanism so as to estimate the additive bandwidth needed beyond the requested due to extra time caused by the control messages propagation delays.

Grant-Sized: There are typically three classes of granted-based scheduling, namely a) the *excess distribution policy*, b) the *gated policy*, and c) the *MPCP-modified policy*.

Maybe the work in [63] constitutes a pioneer towards pursuing the hybrid wireless-optical integration, since it introduces a basis for integrating EPON and WiMAX standards. The authors inaugurate a converged implementation of EPON with WiMAX access networks. They apply the so-called *excess distribution policy* [86], [93]–[95]. The scheme inherits its main properties from the PON field. The overloaded hybrid ONUs share the unused or excess bandwidth left over from hybrid ONUs that are deemed as under-loaded, i.e., having low traffic requests. In this way, the bandwidth distribution becomes more fair and high-utilized.

In particular, the key scheduling mechanism behind the so-called virtual ONU-BS (VOB) is structured as a QoS-aware DBA scheme. Two main target points identify its operational role: a) a perpetual transparency through the data delivery across the hybrid network and b) an integrated QoS provisioning assuming differentiated traffic services guarantees.

The MPCP is adopted as the central coordination mechanism in the optical domain while a simple polling model is employed in the wireless part, where the BS polls the connected Ss about their requests, and then the data delivery from the various Ss to the BS takes place. The DBA scheme maintains a minimum bandwidth portion for BE services to avoid adopting contention intervals. Hence, the whole hybrid bandwidth allocation algorithm is a contention-free scheme.

The main contribution of the mentioned work lies in the proposed QoS-aware DBA scheme, called WE-DBA, which operates as the main component of the SB. The authors distinguish two pairs of communication, the VOB-OLT and the SS-VOB. In other words, the first pair realizes the connection within the optical domain, where the MPCP is adopted untouched, while the second pair refers to the wireless part, where there is no contention stage. In essence, the proposed DBA scheme incorporates a two-stage request aggregation mechanism, where a similar to MPCP mechanism takes place in the SS-VOB pair, where fixed size bandwidth requesting messages are employed to realized a simple polling scheme between the group of the Ss and the VOB, and the MPCP mechanism, incorporating the well-known GATE and REPORT messages is used to connect the VOB with the OLT.

The DBA at VOB assigns bandwidth to each SS based on their bandwidth requests with respect to the priorities. Assuming that the VOB has allocated B bytes bandwidth to the Ss, the DBA initially checks whether this bandwidth portion is sufficient to cover all three service class requirements (including all Ss), let B_1 , B_2 , and B_3 denote the requested needs in bytes of the assumed classes, as earlier mentioned, UGS/EF, rtPS/AF, and BE/BE respectively. The scheme is aware of those needs due to the previous polling cycle. In case that the bandwidth needs overcome the offered bandwidth grant, the UGS/EF requests are served firstly. Then the surplus bandwidth is

calculated, i.e., $B - B_1$. The minimum fixed bandwidth amount for BE/BE bandwidth requirements is subtracted from the surplus bandwidth amount, so it remains $B - B_1 - B_3$. Accordingly, the scheme determines whether the remaining bandwidth grant is able to cover the requests of rtPS/AF of all SSs, i.e., whether it holds $B - B_1 - B_3 > B_2$. If true, the rtPS/AF requests are satisfied and the remaining grant, if any exist, i.e., $B - B_1 - B_2 - B_3$, is granted to the third class, i.e., to the BE/BE. Otherwise, the remaining bandwidth grant, upon the subtraction of the BE/BE bandwidth needs, that is $B - B_1 - B_3$, is shared among the SSs that requested rtPS/AF connections.

The data delivery in the VOB-OLT pair follows the MPCP mechanism. The MPCP REPORT messages carry out the per-class bandwidth request transmitted to the OLT. Hence, the REPORT message consists of three separate bandwidth requests, B_1 , B_2 , and B_3 , as previously mentioned. Initially, the scheme considers the average guaranteed bandwidth, as B_{VOB} for each VOB in terms of bytes as follows:

$$B_{\text{VOB}} = \frac{(T_{\text{cycle}} - n \cdot T_g) \cdot R_{\text{optical}}}{8 \cdot n}. \quad (1)$$

T_{cycle} denotes the granting cycle which is the period of time during which all n VOBs are visited by the DBA. The parameter R_{optical} stands for the (uplink) transmission rate of the (optical) network, while T_g symbolizes the guard time between two consecutive (uplink) allocations. As previously mentioned, the DBA scheme follows the principle of excess distribution, where the granted bandwidth to each i , $1 \leq i \leq n$, VOB is defined as:

$$B_i = \min(B_{\text{VOB}} + B_i^{\text{excess}}, B_i^{\text{req}}). \quad (2)$$

The B_i^{req} stands for the total bandwidth request of the i VOB, which reflects the summation of all service classes requests, while the B_i^{excess} denotes the granted excess bandwidth stemming from the share of the unused bandwidth of the underloaded VOBs. Specifically, the B_i^{excess} portion is the result of sharing the excess bandwidth of all VOBs when it holds:

$$B_{\text{VOB}} > B_i^{\text{req}}. \quad (3)$$

To be more precise, when the (3), is true, then the B_i^{excess} is defined as follows:

$$B_i^{\text{excess}} = \sum_{i=1}^n (B_{\text{VOB}} - B_i^{\text{req}}) / h. \quad (4)$$

The parameter h expresses the number of (overloaded) VOBs, i.e., when $B_{\text{VOB}} < B_i^{\text{req}}$.

For better understanding, a representative example of the DBA operation both at VOB and OLT is following.

DBA at VOB: Considering that the available bandwidth at VOB is 200 bytes and serves 3 subscribers, denoted as SS_1, SS_2, SS_3 . The bandwidth requested from each SS is generated from the three service classes (UGS/EF, rtPS/AF, and BE/BE). Assuming the following bandwidth requests: $SS_{1,1} = 30$ Bytes, $SS_{1,2} = 10$ Bytes, $SS_{1,3} = 40$ Bytes, $SS_{2,1} = 20$ Bytes, $SS_{2,2} = 30$ Bytes, $SS_{2,3} = 40$ Bytes, $SS_{3,1} = 20$ Bytes, $SS_{3,2} = 40$ Bytes, and $SS_{3,3} = 20$ Bytes, Where $SS_{1,1}$ stands for the bandwidth requested generated from the

first service class originated from SS_1 . Thus, it holds that $B_1 = 70$ Bytes, $B_2 = 80$ Bytes, and $B_3 = 100$ Bytes, where B_1, B_2 , and B_3 denote the overall bandwidth requested from all SSs regarding the classes UGS/EF, rtPS/AF, and BE/BE respectively. The DBA algorithm first serves the B_1 request. Hence, the remaining bandwidth is calculated as $200 - 70 = 130$ Bytes. Then, a fixed minimum bandwidth for service class BE/BE is allocated, which is calculated as: $10\% \cdot B_3 = 10$ Bytes. Thus, the B_2 and the remaining bandwidth of B_3 have to be shared $130 - 10 = 120$ Bytes. As the DBA algorithm defines, the B_2 is the next class to be satisfied if it is possible. Therefore, the surplus is $120 - 80(B_2) = 40$ Bytes. Finally, the last 40 Bytes are allocated to the B_3 as follows: $B_3 - (\text{fixed minimum bandwidth for } B_3) - 40$, that is $100 - 10 - 40 = 50$ Bytes.

DBA at OLT: Assuming that the available bandwidth at the OLT is 1000 Bytes. the OLT serves 5 VOBs and each VOB requests $B_1^{\text{req}} = 200$, $B_2^{\text{req}} = 400$, $B_3^{\text{req}} = 100$, $B_4^{\text{req}} = 150$, $B_5^{\text{req}} = 250$ Bytes. Initially, the $B_{\text{VOB}} = 200$ bytes, thus the algorithm calculates the excess bandwidth originated from VOBs which is subject to (3). Both VOB_3 and VOB_4 have excess bandwidth estimated at 100 and 50 Bytes respectively. Note that VOB_1 is completely satisfied while VOB_2 still needs 200 Bytes and VOB_5 needs yet 50 Bytes. Therefore, based on (4), $B_2^{\text{excess}} = 150/2 = 75$ Bytes, and similarly, $B_5^{\text{excess}} = 150/2 = 75$ Bytes, since $h = 2$. At this point, the current excess bandwidth is derived only from VOB_5 and is calculated as $B_{\text{VOB}} + B_5^{\text{excess}} - B_5^{\text{req}} = 25$ Bytes. Following the previous steps, the algorithm, considering (2), allocates the available bandwidth as follows:

$$\begin{aligned} B_1 &= 200 \text{ Bytes, } B_2 = 300 \text{ Bytes} \\ B_3 &= 100 \text{ Bytes, } B_4 = 150 \text{ Bytes} \\ B_5 &= 250 \text{ Bytes.} \end{aligned}$$

The authors in [96] proposed a hierarchical QoS-aware DBA (HQA-DBA) algorithm based on the excess distribution policy. The DBA assigns bandwidth resources based on the user bandwidth requests and priority queue weights. The algorithm can support bandwidth fairness at the OBF (ONU-BS facility) level, as the hybrid ONU is called, and distinguish user QoS requirements. The HQA-DBA operates via efficient collaboration of two DBA algorithms separated in OLT and in OBF. DBA-at-OLT algorithm takes charge of fairly allocating bandwidth resources to each OBF which drives a wireless sub-network. DBA-at-OBF algorithm has to allocate bandwidth to each SS based on traffic bandwidth requests and priorities of the abstract queue.

In [97] the authors introduced the slotted-DBA (S-DBA) for bandwidth distribution in EPON-WiMAX hybrid networks. The main objective of the introduced DBA is to increase the channel utilization by scaling down the signaling overhead. This is achieved by synchronizing the allocation timing of the granted opportunities. The underlying DBA algorithm inherits the excess allocation policy from EPONs [86].

Another example of excess distribution policy is the IID-WBA algorithm in [85]. The algorithm is employed in a WDM-PON combined with multi-channel wireless network. Initially, IIDWBA enters into the first phase, where auto-discovery and registration procedures take place. In the second phase, the

algorithm allocates intra-channel bandwidth to the wireless section. It holds that the excess bandwidth resulting from wireless clients that request less than the minimum guaranteed bandwidth is distributed to the over-loaded clients. In the last phase, the inter-channel bandwidth allocation process comes into play. Again, excess bandwidth across channels is allocated to wireless clients having more bandwidth requirements than the guaranteed amount. In essence, IIDWBA runs at the top of the core DBA scheme in the hybrid network, hence it is limited to distribute channel resources to the connected wireless users.

In the *gated policy* the grant size for a hybrid ONU is simply the queue size reported by that ONU. This scheme provides low average delay but does not provide adequate control to ensure fair access between ONUs [76]. The work in [64] presented an interesting testbed incorporating a combination of GPON and WiMAX systems. The provided DBA is implemented inside the control bridge connecting the optical and wireless interfaces. The service manager, the component that runs the DBA, is a management entity which has the knowledge of users' SLAs. The allocated bandwidth is dynamically changed to ensure just enough bandwidth provisioning for profiled video-on-demand (VOD) services. Specifically, the bandwidth usage, as a function of time for each video, is known in advance and stored in a database associated with video content. Hence, the users' requests are *a priori* known, so the DBA applies a gated-based policy to meet the (predefined) VOD requests of each user.

Similarly, the authors in [80] proposed a novel framework, called WiMAX-VPON, for realizing layer-2 virtual private networks (VPNs) and provide a VPN-based dynamic bandwidth allocation (VPN-DBA) scheme that is installed at both OLT and hybrid ONUs, to arbitrate the transmission of hybrid ONUs over the upstream optical channel, and the transmission of SSs over the uplink wireless channel, respectively. Each hybrid ONU calculates the aggregated rates of the admitted real-time flows and the total reserved VPN BE rates, to determine the time share for a flow. To protect real-time traffic from being shared with best effort traffic, the hybrid ONU divides each transmission cycle into two sub-cycles, real-time and best-effort sub cycles, and each BE sub-cycle is further subdivided into sub-cycles. The VPN-DBA scheme at hybrid ONU estimates the amount of bandwidth required to satisfy each admitted flow in each frame. Thus, the estimated guaranteed bandwidth for a real-time flow launched by SS and in each polling interval is determined and then the allocated bandwidth for real-time flow and for BE traffic is calculated. The VPN-DBA at OLT divides the transmission cycle and calculates the allocated bandwidth in the same manner as the hybrid ONU does. The proposed VPN-DBA scheme takes account the physical layer (PHY) burst profile associated with each wireless link such that a statistical QoS guarantee is achieved. A similar DBA is adopted in [82] too; however, in [82] a comprehensive analysis is provided where the average packet delay, the per-class average queue size, and the optimal frame length are computed using queuing theory. The accuracy of the provided model is validated using the OMNET++ simulator [98].

The authors in [84] adopted the previous VPN-DBA scheme which is installed at the OLT and VPN-DBA and divides each uplink cycle into two sub cycles. The first sub-cycle is used to

allocate guaranteed bandwidth for admitted EGS (emergency grant service) and real-time traffic, whereas the second sub cycle is used to allocate BE traffic per VPN. However unlike in [80], where EGS was not supported, if the uplink channel is overloaded and an emergency event occurs, a call preemption mechanism is designed to borrow enough bandwidth from the BE quota to serve the incoming EGS flow. The borrowed bandwidth is then re-allocated back to the BE traffic once all emergency are served and satisfied.

A cooperative QoS control scheme is described in [99], where the proposed WiFi network consists of a generic PON, e.g., EPON, and a wireless WLAN. This scheme utilizes the scheduling information the APs possess to inform the ONUs about the bandwidth demands of all wireless clients. Accordingly, each ONU takes into account this information on reporting its traffic requests. In this way, the transmission latency of the arrival traffic becomes shorter.

The work in [68] endeavors an ambitious project. It aims at integrating PON framework, especially an EPON, with LTE. The project sound quite compelling, however, there are many unsolved issues remain, such as the common QoS provisioning. The QoS model of EPS, which was standardized in 3GPP release 8, is based on the logical concept of an "EPS bearer" [10]–[13]. The term "bearer" refers to a logical IP transmission path between the SS and the EPC with specific QoS parameters (capacity, delay, packet loss error rate, etc.). Each bearer is assigned a single QoS class identifier (QCI) so as to identify the QoS characteristics that the EPC supports. In general, bearers can be classified into two categories based on the QoS levels they support: Guaranteed bit rate (GBR) and Non-GBR. Each QCI bears the connection type, i.e., either GBR or Non-GBR, the priority level, the packet delay threshold and the acceptable packet loss rate. Nevertheless, the QoS provisioning in EPON framework is different. The QoS requirements are met via service type queues, which store and schedule bandwidth demands. In other words, EPON ensures QoS through prioritization where packets are classified, stored in different priority queues and, then, scheduled for service according to their priority. On the other hand, LTE supports guaranteed QoS through logical bearer reservation where each router/node on the RAN/EPC is configured to forward the packets of different IP flows based on their bearer-IDs (QCIs) in which resources are reserved (queue space, queuing management strategy, scheduling strategy) accordingly. Thus, an efficient QoS mapping mechanism is required to ensure a common QoS policy in the converged network. The authors in [68] identify the criteria so as such a vision, i.e., a converged EPON-LTE next generation network, could be viable:

- 1) The main network entities in the optical domain, i.e., both ONU and OLT, have to reconfigured to directly identified the standardized QCIs of all eight LTE's QoS characteristics.
- 2) The scheduler operating in optical domain should be aware of the configured QCI values associated with each IP flow. Hence, the scheduler should apply equal policies to connections coming from both wireless and optical connected users.

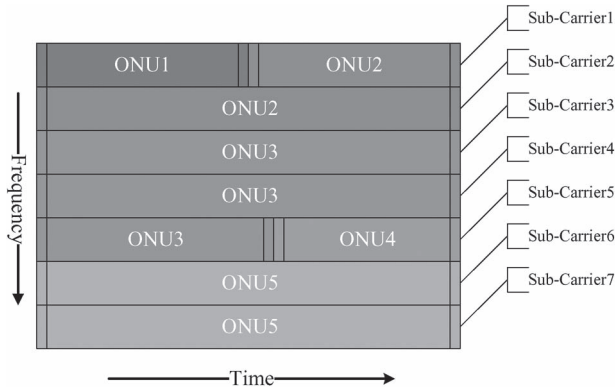

Fig. 30. A paradigm of applying ONUs request to different OFDM sub-carriers.

- 3) Scheduling policies that apply a cycle-based packet forwarding, as the most DBA schemes proposed, should be extensively changed to take into account the whole duration of a flow that could be longer than the cycle assumed.
- 4) The QoS mapping policy should be accompanied with a global admission and congestion control mechanism. This mechanism has to be located in a central module, governing both wired and wireless connections.

Speaking about PON-LTE integration, a set of interesting investigations towards the integration of PON and LTE, using the gated policy, are presented in [67]. By means of simulation, using the OPNET simulator [100], the authors conducted multiple scenarios to examine whether the QoS support in a hybrid EPON-LTE network is endured. Despite the interesting results presented, the contribution of this work is limited to various simulation scenarios neglecting to provide neither a solid QoS mapping, nor an efficient DBA algorithm.

Applying the OFDM technique as an access method defines the compelling orthogonal frequency division multiple access (OFDMA) multiplexing strategy, whereby different users are assigned to different OFDM sub-carriers. Fig. 30 illustrates a possible paradigm of the above technique, while Fig. 31 demonstrates how this technique could be applied into a TDD-based WiMAX frame. Recent research works indicate the applicability of the OFDMA technique in PONs, paving the way for high capacity, long-reach and cost-effective operation for PONs [101]. Currently, the ongoing design of OFDM-based DBA schemes entail gated policy.

A different approach on forming transmission schedule subject to the transmission control protocol (TCP) performance was proposed in [102]. The authors face the packet ordering issue in the transport layer which may negatively affect the network congestion, since the assumed FiWi composes of an EPON and a mesh wireless network. The IPACT-MPR was introduced to reduce the undesirable long waiting delay. It adopts the limited service where the OLT grants the requested windows size that equals the instant buffer length.

Another technique identified as hierarchical scheduling is *MPCP-modified* DBA schemes. The unique characteristic of this category seems to be the modification that takes part in the

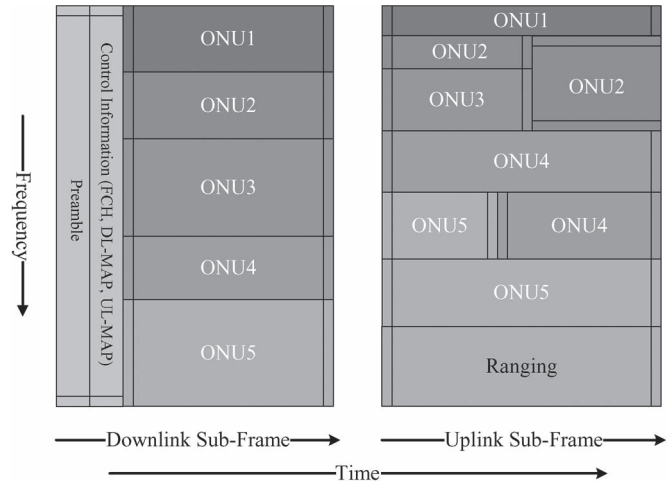

Fig. 31. A TDD-based WiMAX frame accommodating ONU requests.

MPCP mechanism. Usually, MPCP-modified schemes manipulate either the GATE or the REPORT message structure to provide an efficient hierarchical DBA algorithm. However, this custom design comes at expense of the standardization.

The fault-tolerant property is studied and its impact is identified in hybrid wireless-optical networks in [60]. The risk-awareness is a critical feature in modern access networks affecting the user resilience and connectivity. Even though the typical topology of a PON is the tree, and therefore, the core network of a hybrid network remains the tree, many topology alterations have been proposed, as discussed in Section V, to address the case of single or multiple network failures. The dual-router concept is raised in [60], incorporated as a double OLT support, so as to protect the optical domain against CO failures. Moreover, the authors of this work propose the insertion of an intermediate network between the backhaul and the front end networks, creating in this way an optical-optical-wireless architecture. To support such a multiform network topology, a three-level DBA algorithm is introduced, performing in a distributed manner. The so-called BS bandwidth allocation (BSBA) component is located at each SS. Its role reveals an innovative feature; the algorithm is responsible for adjusting the WiMAX frame size in line with delay requirements of running connections independently in each SS. Specifically, the frame size (F_i) of each i SS is defined as:

$$F_i = \min(2 \cdot C_j) \quad (5)$$

where C_j denotes the delay requirement of the j connection in the i SS. The DBA running at the ONU, namely ONU bandwidth allocation (ONUBA) fastens the wireless part with the inner optical domain that is structured by multiple subOLTs. Hence, ONUs are responsible for sending bandwidth requests to subOLTs and receive bandwidth grants from them. The behavior of the ONUBA is differentiated compared to the BSBA regarding the handling of service types. It is worth mentioning that the communication method of the ONUs with the subOLTs comes though via manipulated REPORT messages. Among others, each REPORT message includes the requested bandwidth, statistics, expected rates, and predicted amount of traffic requests. When a REPORT message reaches the outer

optical domain, at the subOLTs, the so-called subOLTBA is triggered in two steps. First, it assigns the requested bandwidth per service type. Subsequently, it attempts to satisfy all bandwidth requests of the remaining queues, e.g., the predicted ones. Any connection that fails to be accommodated is dropped. The proposed scheme is evaluated by means of simulation in comparison with a simplified, non-unified EPON-WiMAX allocation scheme. In spite of the evaluation results, such as the drop ratio, seem promising, the scheme lacks in standardization, since it manipulates both the WiMAX frame cycle and the REPORT message, while it fails to provide solid solutions on the prediction details as well as the priority weights.

Another hierarchical DBA scheme entailing a modified MPCP mechanism is the scheme proposed in [90]. To provide QoS guarantees it suggests a modified MPCP scheme accompanied with a two-stage admission policy. The modified MPCP scheme relates exclusively on the optical domain. Initially, assuming that the bandwidth grants have already computed using either a TDMA policy or the well-known IPACT [103] algorithm, the OLT calculates the cycle length of each k hybrid ONU:

$$T_{\text{cycle}} = \sum_{i=1}^k \left(\frac{BW^i}{R_{\text{optical}}} + T_g \right) \quad (6)$$

where BW^i denotes the granted bandwidth allocated to the i ONU, T_g stands for the guard time, and R_{optical} is the transmission rate of the (uplink) optical link. Subsequently, the interval between two successive cycles is calculated and stored in the modified GATE message as a new field. Thus, the ONU is aware of the time duration the current polling procedure lasts and becomes able to make AC decisions on newly incoming connection requests originated from the SSs. Nonetheless, the above analysis, intuitively, predispose that the ONU queue is unlimited and the bandwidth demands BW^i are entirely satisfied. The combination of the above remarks degrades the feasibility of the proposed framework and raises questions about its applicability.

The authors in [104] proposed the video MAC protocol (VMP) to support the wireless users of FiWi networks with prerecorded video downstream. The FiWi network is structured by an EPON and an IEEE 802.11n wireless LAN. MPCP is employed to coordinate the OLT and the various enhanced ONUs. The OLT incorporates extended versions of REPORT and GATE messages. In the extended REPORT frame the VMP makes use of the reserved bits to transfer control information stemming from the existing wireless channels. Concurrently, 39 octets, reserved from the GATE message, are utilized to carry out scheduling information from the OLT to the connected wireless stations. Moreover, the suggested scheme engages a frame fragmentation method to effectively transfer MAC frames within the hybrid network and a video prefetching technique to *a priori* reserve video content to wireless stations. The protocol offers notable video traffic performance in terms of mean throughput and delay.

Prediction-Sized: Predicting the incoming traffic to decrease the delay bound is not an unusual strategy in access networking. By estimating the traffic requested by a traffic aggregation unit

such an ONU, the scheduling efficiency could be significantly improved. EPONs exhibit a perfectly suitable play ground to apply traffic prediction, since a significant time gap occurs between the transmission and the reception of requesting control messages, i.e., REPORT, resulting in considerable new arrivals that have to wait for the next cycle to be registered for transmission. Usually, traffic prediction is applied to estimate the additional traffic generated during the time between the REPORT transmission at the ONU and the start of the next grant for that ONU [105]–[109]. Nevertheless, traffic prediction imposes a noticeable challenge. The performance of traffic prediction is seriously depends on the traffic pattern. An accurate traffic predictor may result reduced delays in the network applied, but an inefficient prediction method could jeopardize the network stability, inducing, for example, low rates of channel utilization.

We can classify two main categories of predicting in hybrid wireless-optical networks. The *holistic prediction* is identified when the prediction is based on the wireless or/and optical transmission rate. In this case, the predicted amount of traffic, in bytes, is obtained by multiplying the time elapsed since the reporting moment, usually in the ONU side, by the transmission rate of the medium technology the traffic is originated. For example, suppose that at time t_0 a REPORT message is forwarded from a hybrid ONU to the OLT reporting the traffic requested by the SSs attached to the ONU. If the GATE message reaches the ONU at time t_1 , and during this time interval $(t_1 - t_0)$ the wireless link, between the SSs and the hybrid ONU is active, delivering more traffic requests to be accommodated, a holistic predictor results $(t_1 - t_0) \cdot R_{\text{wireless}}$ bytes as a surplus traffic prediction, where R_{wireless} is the transmission rate of the wireless link. On the other hand, the prediction method that maintains either historical or statistical data to provide the estimated amount of traffic is classified as *traditional prediction*.

An example of *holistic prediction* is the traffic-prediction-assisted DBA [59], [78] which studies the impact of predicting the incoming traffic in hybrid ONUs in an interesting perspective. By adopting the *pre-assignment* approach each ONU request not only the actual amount of bandwidth based on the traffic present, but the required bandwidth for transmitting data packets that have not yet arrived in the ONU stemming from the SSs. The intelligence of the method is further strengthened by appropriately align the cycle length of EPON and WiMAX frames. Assuming that there is no local traffic in the hybrid ONU, by users connected via optical interface, the received data at the hybrid ONU is exclusively generated by the SSs. Accordingly, the hybrid ONU should be aware of the accumulated uplink requests, an ongoing WiMAX frame encloses, so as to predict the amount of traffic arriving until the next EPON cycle. Thus, the operational condition for adequately applying a prediction method is that the WiMAX frame length should be longer than the EPON cycle length. Consequently, the amount of bandwidth, let it B , the hybrid ONU requests from the OLT, is given as follows:

$$B = Q + P(t) \quad (7)$$

where Q denotes the actual amount of data existing in the hybrid ONU queue at the time the REPORT message is transmitted to the OLT and $P(t)$ is the predicted incoming traffic during

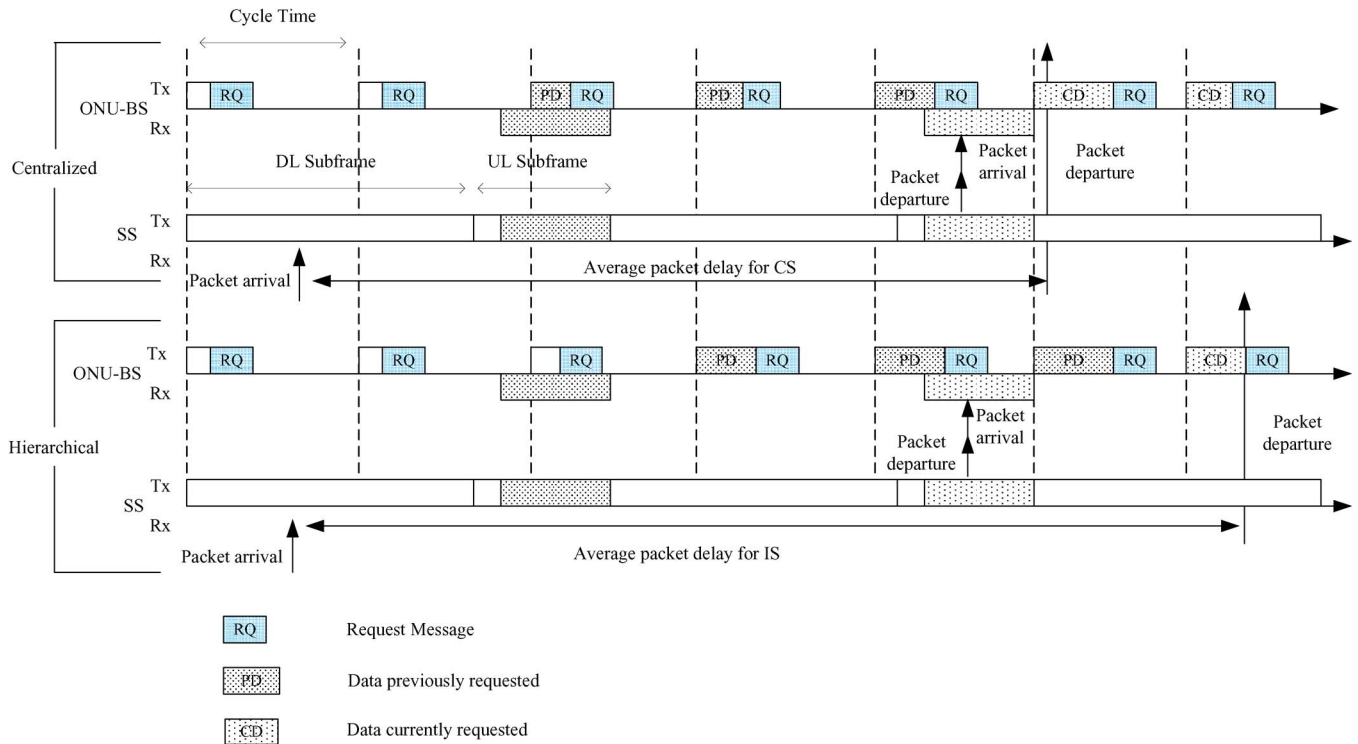

Fig. 32. Centralized vs. Hierarchical scheduling.

time t , which symbolizes the time between the transmission of the REPORT message to the beginning of the next grant.

The proposed algorithm operates in two phases; the first phase is called inter-ONU scheduling and the following intra-ONU scheduling. First, the inter-ONU scheduling is employed, running at the OLT, where it is calculated the amount of B including the predicted amount of traffic. At this phase, the algorithm does not define how the granted bandwidth is shared among the various service classes. It only defines the way of deciding about the traffic allocated to each hybrid ONU in terms of bytes. The prediction method devised is quite simple. Given that the cycle length of EPON and WiMAX are coincided, the OLT performs the prediction calculation at time t . The prediction result depends on the time relation between t and the beginning of the (forthcoming) WiMAX frame cycle. Specifically, if the beginning of the WiMAX frame cycle is later than t , the granted bandwidth is equal to Q . Otherwise, the traffic amount of $P(t)$ is larger than zero and equal to the WiMAX transmission rate, in bit per second, multiplied by the time elapsed between the t time and the beginning of the forthcoming WiMAX frame cycle.

The performance evaluation of the traffic-prediction-assisted scheme reveals its potential to reduce the average delay, even though the traffic fed into the simulator is deemed as simplified, since it generated by a combination of Poisson traffic (EF) and self-similar traffic models (AF, BE).

The prediction-based fair excessive bandwidth allocation (PFEBA) mechanism [57] is initially designed for EPON systems, nevertheless, the authors indicate its applicability to hybrid wireless-optical networks too. It entails a prediction process based on the hybrid ONU history, so it falls into the *traditional class*. The prediction process is determined by the

so-called *ONU unstable degree factor*. This factor is defined by the traffic variance each ONU requested by the REPORT message in the past. The predicted value of each ONU receives the value of the previous cycle modified by its magnitude of the unstable degree factor in conjunction with the waiting time the ONU receives between the REPORT transmission and the GATE reception. The results are obtained by conducting simulation experiments assessing the mean packet delay, the drop ratio, and the queue length. The evaluation includes the comparison of the proposed scheme versus the pure MPCP-based IPACT [103], hence the assessment is deemed as limited.

Centralized: The work in [61] inaugurates the principle of the *centralized scheduling* in EPON-WiMAX paradigm. The work identifies a subtle difference towards hierarchical scheduling in hybrid wireless-optical networks, when the core network is incorporated by an EPON. Fig. 32 illustrates the centralized vs. the hierarchical scheduling. To shorten the mean packet delay the centralized scheduling concept endeavors to transfer the control to the OLT profoundly. Unlike the hierarchical concept, where the DBA control is distributed in both OLT and hybrid ONU, CS mechanism delegates the entire DBA tasks to the OLT. Intuitively, this action affects the SS-ONU pair. According to centralized concept, the OLT completely governs the bandwidth allocation of each SS. In particular, the role of the hybrid ONU is understated in a way that each hybrid ONU simply forwards data packets and control messages instead of making independent decisions considering the bandwidth allocation of the SSs. Thus, the OLT is responsible for granting GATE messages directly to the SSs, receiving requests from the SSs in form of REPORT messages, piggybacked into the uplink data in the ONU side, and to apply a global admission control. Extensive simulation results indicate the superiority

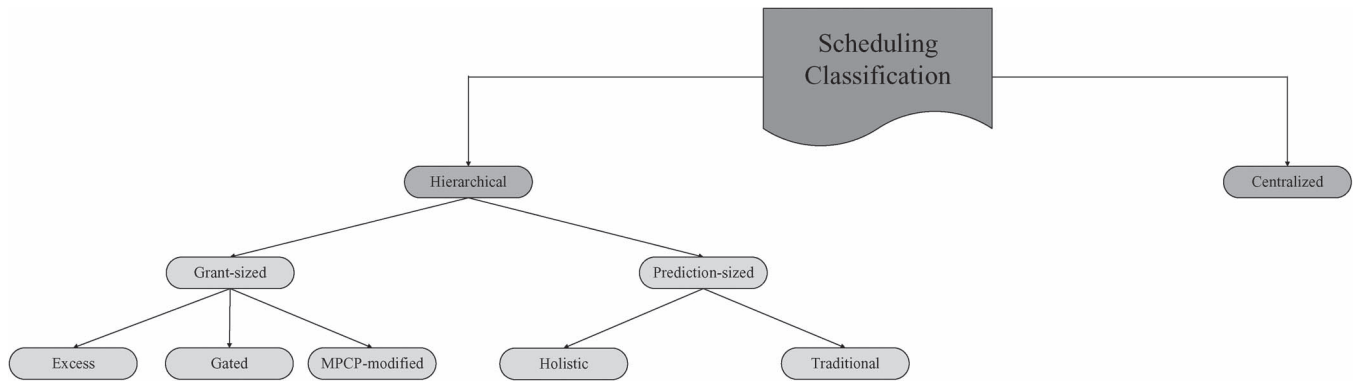

Fig. 33. Scheduling classification.

of the centralized over the hierarchical concept in terms of mean packet delay and link throughput between the OLT and the splitter, however, the work focuses only to the scheduling behavior, neglecting to describe neither the accompanied admission policy, nor the QoS mapping mechanism.

Discussion and Remarks: According to [61] the centralized scheduling outperforms hierarchical in terms of mean packet delay and network throughput. Also, it provides better QoS provisioning. Nevertheless, centralized scheduling may face scalability issues when large number of users is connected to SSs. Moreover, the equipment cost of supporting centralized control may be higher. Accordingly, the hierarchical scheduling poses as the most favorable technique, providing scalable and cost-effective DBA processing. However, an efficient DBA mechanism should be sophisticated enough to meet the demanding bandwidth needs of modern services and applications. A common drawback identified in the most DBA schemes proposed has to do with the cycle-based assumption. It is a common practice to assume a static and predefined cycle for both optical and wireless polling schemes. Nevertheless, this assumption is not realistic. More efficient DBA frameworks are needed to provide flexible scheduling considering unpredictable and dynamic polling processes. Moreover, the heterogeneous propagation delays have to be taken into account, devising a fair policy by effectively treating user connections according to QoS requirements.

Fig. 33 displays the scheduling classification. Tables V and VI summarize a performance comparison of the QoS blocks and the most representative DBA frameworks respectively.

VIII. NEW TRENDS

In this Section new trends, applications, and implementations are presented towards the development of advanced hybrid wireless-optical networks.

Hybrid PONs With Small Cells: Mobile BackHaul (MBH) systems became quite attractive due to the proliferation of modern mobile devices such as smartphones and tablets. Bearing in mind that the access network of the future will be an organic mixture of current and new technologies, various cell sizes, and different physical locations, the role of MBH could be of paramount importance in the tomorrow last mile architecture [110]. On the other hand, noticeable combinations of MBH implementations within PON paradigms have recently emerged

showing the roadmap to the forthcoming access network solutions. In addition, given that latest releases of LTE using small cells have been emerged as an important evolution to provide the necessary means to accommodate the anticipated huge traffic growth [111], [112], new, promising trends are identified towards the integration of advanced PONs with LTE small cells.

Maybe, the most distinguishing paradigm of the MBH penetration in the PON technology is the OFDMA-PON [113]. Frequency-domain subcarriers can be utilized to incorporate low-latency virtual point-to-point links with sub-wavelength granularity [114], [115]. Another example can be found in [116], where a femtocell is demonstrated using GPON backhaul. The work discusses on energy efficiency aspects. According to its findings, the deployment of femtocells does not necessarily lead to a lower total network power consumption; however it can certainly result in a significant increase of both access data rates and energy efficiency in areas with high population densities.

Channel or capacity allocation in such networks entails dynamic assignment [117]. Estimated traffic in small cells is expected even more bursty than the versatile traffic that is generated in the conventional access networks. In addition, coordination is required in both uplink and downlink direction. Thus, the integration of PONs with small cells seems to be quite promising [118].

Virtualization: Undoubtedly, contemporary access networks are progressively growing in terms of size, users, and supported applications. In this way, the network management is expected to become a laborious task. One of the latest trend addressing the management of the future access networks is the virtualization. Its purpose is to mitigate the pressing from the current applications and services to ensure an adequate QoS in the existing access networks and to facilitate the installation of new services as well [119]. Virtualization is defined as the application of logical structure entailing multiple Virtual Networks (VNs) that co-exist on a cohesive physical network infrastructure [120]. Each VN composes virtual nodes and links. By applying virtual structures the responsibility of the traditional Internet Service Provider (ISP) is divided into two independent roles: the Infrastructure Provider (InP) and the Service Provider (SP). The former provider offers the network resources; the latter provider distributes the resources to the network consumers, i.e., users, applications, control management, and coordination. To ensure sufficient resources across all infrastructure recent

TABLE V
PERFORMANCE COMPARISON OF QoS BLOCKS

| <i>Criteria</i> | | <i>Efficiency</i> | <i>Standard-compliant</i> | <i>Complexity</i> |
|-------------------------|---|-------------------|---------------------------|--------------------|
| <i>QoS Mapping</i> | Triple Priority (Optical-based) | Medium | Yes | Medium |
| | 8-Queues (Optical-based) | High | Yes | Low |
| | CONT-based (Optical-based) | Medium | Yes | Medium |
| | Wireless-based | High | Yes | Low |
| | Modified | High | No | High |
| <i>Criteria</i> | | <i>Efficiency</i> | <i>SLA support</i> | <i>Flexibility</i> |
| <i>QoS-Provisioning</i> | Standard (Strict Priority) | Low | No | Low |
| | Two-Stage (Strict Priority) | Medium | No | Medium |
| | Mixed (Strict Priority) | Medium | No | Medium |
| | Minimum Best Effort | High | No | High |
| | Admission Control | High | Yes | Medium |
| | Cost-based | Medium | No | High |
| <i>Criteria</i> | | <i>Efficiency</i> | <i>Standard-compliant</i> | <i>Complexity</i> |
| <i>Scheduling</i> | Excess (Hierarchical/Grant-sized) | High | Yes | Medium |
| | Gated (Hierarchical/Grant-sized) | Medium | Yes | Low |
| | MPCP-modified (Hierarchical/Grant-sized) | High | No | High |
| | Holistic (Hierarchical/Prediction-based) | Dependable | Yes | High |
| | Holistic (Hierarchical/Prediction-based) | Dependable | Yes | High |
| | Centralized | Low | Yes | High |

research efforts devised virtualization and planning approaches [121], [122]. In the context of a modern hybrid wireless-optical network, the aim is to identify the virtual topology, determine the virtual resources, and implement a fair resource allocation over the wireless and the optical backhaul. The performance of the virtualization techniques seem to be promising in terms of energy efficiency and mobility requirements. In addition, if cloud computing services are involved as an essential element of the whole infrastructure, the potential of utilizing virtual structure and components is developed into intriguing direction [123].

Survivability and Protection: Due to hybrid architecture of integrated wireless-optical access networks, several failures of various components can cause data loss, disconnections, and service disorientation. Survivability is defined as the ability of the network to provide seamless connectivity and service provisioning after a failure [124]–[126]. This term has emerged as quite popular in hybrid wireless-optical network since it engages both optical protection, such as full or partial PON duplication [124], backup of fiber lines [127], and wireless protection, such as routing protection techniques assuming a wireless mesh infrastructure [128], [129]. Another interesting technique is the placement determination to facilitate safe

routing paths and minimize the required number of equipment [130], [131]. Nonetheless, survivability, protection, and equipment placement constitute compelling trends affecting the cost-effectiveness, the power consumption [132], and the credibility of modern hybrid access networks.

Elastic and Adaptive FiWi: Because of the great success of OFDM in wireless and wireline systems, it is currently being considered for optical transmission and networking [133]. In addition, current WDM optical architectures pose limitations in terms of flexible bandwidth allocation and coarse granularity. For example, it is not feasible to manipulate the spectrum bounds of a channel since all channels are statically configured upon their installation. Hence, considerable portion of bandwidth is wasted when a channel supporting 100 Gb/s is allocated to carry out a traffic stream of 70 Gb/s. To remedy this situation optical channels capable of dynamically being configured to support flexible data rates have developed by employing one of three possible popular methods: a) Spectrum-Sliced Elastic Optical Path Network (SLICE), where an optical path is established having the capability to utilize as much sub-carriers as it exactly needs, b) Flexible Optical WDM (FWDM), where single-carrier modulation combined with OFDM-based multi-carrier modulation schemes offer adaptive data rates in

TABLE VI
CLASSIFICATION OF THE MOST CHARACTERISTIC DBA SCHEMES

| | Optical technology | Wireless technology | QoS mapping | QoS provisioning | Scheduling |
|--|--------------------|---------------------|---------------------------|------------------------|---|
| I. S. Hwang <i>et al.</i> , [57] | EPON | WiMAX | Triple priority | Mixed strict policy | Hierarchical Prediction-sized traditional |
| A. A. Mirahmadi <i>et al.</i> , [59, 78] | EPON | WiMAX | Triple priority | Two-stage | Hierarchical Prediction-sized holistic |
| A. Ahmed <i>et al.</i> , [60] | EPON | WiMAX | Wireless-based | Mixed strict policy | MPCP-modified |
| B. Jung <i>et al.</i> , [61] | EPON | WiMAX | Wireless-based | Standard strict policy | Centralized |
| K. Yang <i>et al.</i> , [63] | EPON | WiMAX | Triple priority | Minimum best effort | Hierarchical Excess |
| S. Ou <i>et al.</i> , [64] | GPON | WiMAX | CONT-based | Cost-based | Gated |
| M. A. Ali <i>et al.</i> , [68] | EPON | LTE | 8-Queue | Unspecified | Gated |
| I. S. Hwang <i>et al.</i> , [77] | EPON | WiMAX | Triple priority | Two-stage | Gated |
| W. Lim <i>et al.</i> , [79] | OFDM-PON | LTE | 8-Queue & Triple priority | Unspecified | Gated |
| A. R. Dhaini <i>et al.</i> , [80] | EPON | WiMAX | Wireless-based | Admission Control | Gated |
| A. Ahmed <i>et al.</i> , [81] | EPON | WiMAX | Wireless-based | Admission Control | Gated |
| A. R. Dhaini <i>et al.</i> , [82] | EPON | WiMAX | Wireless-based | Admission Control | Gated |
| A. R. Dhaini <i>et al.</i> , [84] | EPON | WiMAX | Wireless-based | Admission Control | Gated |
| N. Moradpoor <i>et al.</i> , [85] | WDM-PON | WiMAX or Wi-Fi | Modified | Minimum best effort | Gated |
| L. Jiang <i>et al.</i> , [96] | EPON | WiMAX | Triple priority | Two-stage | Hierarchical Excess |

installed optical paths, and c) Data-Rate Elastic Optical Network, where the same techniques as in SLICE and FWDM are used but the design is limited by a fixed-grid spectrum allocation [133], [134]. Given that inaugurating elasticity and adaptation into the optical domain is expected to yield significant cost savings and enhanced availability associated with the efficient and scalable use of spectral resources in the optical network, hybrid wireless-optical networks could be dramatically advanced by adopting elastic PONs [135]. For instance, in [136] a WDM RoF PON was proposed. The authors concluded that it contributes on coverage area scaling up, signal clearance, and increased bit error rate. Thus, injecting elasticity in modern FiWi systems constitutes one of the most intriguing research trends, which it may allow more users and applications with the same or even less cost.

IX. CHALLENGES

Next generation hybrid wireless-optical networking is currently experiencing a remarkable proliferation. As it constitutes a compelling alternative solution for high-performance access networking, it has to be efficient and effective enough to compete against the mature, already established and low cost access architectures such as xDSL, standalone PONs, and 4G

wireless platforms. Its unique characteristics are sufficient to allow the transformation from a testbed technology to a mature, cost-effective and commercial product. However, there is still work to be done. Even though the literature looks abundant of research undertakings towards the correct direction, still there are many impairments looking for remedy. In this Section, we enumerate future challenges and opportunities towards wireless-optical integration following the aspects raised in [75], [137]–[140].

One of the most critical issues, that was never explored so far, is the impact of propagation delay diversity. The already conducted work regarding development of hybrid DBA schemes assumes a fixed, predefined cycle for designing polling mechanisms in both optical and wireless domains, e.g., the fixed cycle MPCP. However, this assumption degrades the applicability of the DBA scheme. Hence, more efficient, dynamic, and flexible DBA schemes are required to address the future bandwidth-starving services and applications.

QoS provisioning plays a key role in hybrid wireless-optical access networks. It governs the quality of the offered services and may seriously influence the network desirability in the telecom market arena. Most of the works found in the literature propose either a strict policy or an independent AC. To support adequate QoS services, a modern hybrid wireless-optical

should be accompanied with an integrated AC. This module should be carefully monitor, control, and govern call connections in the whole network applying an effective policy. The policy has to take into account fairness issues, SLAs, IP connections, throughput and delay guarantees, and individual contracts. Fairness issue has not been extensively addressed so far. For instance, efforts in [141] provide fairness provisioning; however it is limited to the mesh wireless domain. More efforts are needed to ensure fairness in FiWi access implementations. Moreover, extensive simulation and analytical frameworks are needed to identify the reliability and the effectiveness of an integrated AC under varied traffic conditions. Consequently, an integrated AC mechanism that applies to both EPON and WiMAX, which has not been seen in the literature, would be an interesting topic to investigate into.

Telecommunication systems interwork with the aim to support and satisfy in the most appropriate manner users' requirements, preferences and constraints. To handle excessive traffic demand, providers deploy new network elements and hardware components, leading, thus, to increased amounts of energy required for their constituent operation. Access network constitutes a major energy consumer. It is estimated that access networks are responsible for the 70% of the overall telecommunication networks energy consumption [142]. Despite the fact that PONs, holding the core part of the modern hybrid wireless-optical networks, are deemed as light energy consumers, effective energy efficient protocols and schemes are needed to reduce the consumption in hybrid wireless-optical networks. Even though several efforts push for green FiWi networks in the routing level [143]–[152], so far, the development of energy-efficient access FiWi networks remains unexplored, regardless of the fact that the ITU pays high attention to development of high-performance energy efficient DBA schemes for new generation PONs. For instance, the study of how the sleep mode technique could be effectively applied to the hybrid ONUs could be a challenge for future work.

Prediction and estimation techniques could be beneficial in the direction of tackling high propagation delays. As mentioned earlier, the usage of polling schemes, such as the MPCP, entails interconnection via control messages, as the GATE and REPORT. The function of appropriate prediction techniques may address this pitfall. However, the prediction methods found in the literature are limited to apply short-term bandwidth estimation, i.e., for the next cycle or frame. Long-term prediction techniques are required for estimating volatile variable-bit-rate traffic employing high levels of cognition such as fuzzy logic, neural networks, and genetic programming. As an example, the development of a long-term predictor based on statistical data originated by real traffic patterns would be an interesting research topic.

Most of the proposed DBA schemes for hybrid wireless-optical networking consider only traffic generated by the wireless domain. However, this design could lead to serious deficiencies, if local traffic is, also, considered. Hence, an integrated DBA scheme is necessitated to support both traffic requests. To this end, it is interesting to study the structure of the polling scheme incorporated in the PON side, e.g., MPCP, when traffic requests arrive from both optical and wireless domains.

The integration of optical and wireless access networks exhibits a unique feature; that is the interconnection of optical domain with various wireless platforms. Interconnections between PONs and WiMAX, WiFi, and LTE are already demonstrated. Given that wireless personal area networks (WPANs) gain progressively attention providing multitude, popular services and applications, the interconnection between optical platforms like PON with WPANs seems promising. A WPAN is a simple, low-cost communication network that allows wireless connectivity in multiple applications, incorporating, for example, a wide-area sensor network [153]. The interconnection between a PON and a WPAN could afford augmented merits such as application interoperability, multi-user access, high-performance monitoring system support, e.g., high definition video surveillance, and long-reach coverage of wide-area sensor networks. The integration of the IEEE 802.15.4 standard [154] with several other platforms such as EPON, GPON, WiMAX, and LTE in a common internetworking support remains an open challenge.

Finally, optimization could pave the way of developing commercial hybrid network components. Optimized DBA schemes may lead to high rates of utilization, which in return may allow maximum exploitation of the available resources offering a financially affordable ratio between spent money and revenue. Optimized techniques may be applied into several areas. For example, the order of treating bandwidth requests may be further studied so as to provide optimal schedules. Another example lies in the defined downlink-to-uplink ration regarding the used wireless platform. Various works indicate that adequately adjusting this ratio may lead to optimal or near-optimal resource allocation [155], [156]. As a last note, various scheduling techniques could be studied and implemented to address the diverse scheduling needs coming from combining different technologies and architectures.

X. CONCLUSION

The integration of optical and wireless technologies is experiencing an ongoing proliferation. In this study, we endeavor to reveal the main characteristics of the hybrid wireless-optical networks giving emphasis to the functional modules and network dynamics. In particular, essential background information towards the integration of optical and wireless technologies was provided, integrated hybrid architectures were presented and compiled, and convergence design options and properties were classified and discussed. Moreover, proposed bandwidth allocation schemes were distinguished and presented in accordance with the most QoS-aware mechanisms and components. New emerging trends were highlighted in terms of advanced services and hybrid network capabilities. Illustrative examples and detailed tutorial content accompany the most compelling issues on exploring the components of the hybrid wireless-optical networks. Based on the remarks raised, we provided intriguing challenges and future directions in detail.

REFERENCES

- [1] A. Shami and M. Maier, Eds., *Broadband Access Networks: Technologies and Deployments*. New York, NY, USA: Springer-Verlag, 2009.
- [2] P. W. Shumate, "Fiber-to-the-home: 1977–2007," *J. Lightw. Technol.*, vol. 26, no. 9, pp. 1093–1103, May 2008.

- [3] L. G. Kazovsky, W.-T. Shaw, D. Gutierrez, N. Cheng, and S.-W. Wong, "Next-generation optical access networks," *J. Lightw. Technol.*, vol. 25, no. 11, pp. 3428–3442, Nov. 2007.
- [4] *IEEE Standard for Local and Metropolitan Area Networks Part 16: Air Interface for Fixed Broadband Wireless Access Systems*, IEEE Std. 802.16-2001, Apr. 8, 2002.
- [5] *IEEE Standard for Local and Metropolitan Area Networks Part 16: Air Interface for Fixed Broadband Wireless Access Systems-Amendment 2: Medium Access Control Modifications and Additional Physical Layer Specifications for 2–11 GHz*, IEEE Std. 802.16a-2003, Apr. 1, 2003.
- [6] *IEEE Standard for Local and Metropolitan Area Networks-Part 16: Air Interface for Fixed Broadband Wireless Access Systems*, IEEE Std. 802.16-REVd/D5-2004, May 13, 2004.
- [7] *IEEE Standard for Local and Metropolitan Area Networks-Part 16: Air Interface for Fixed and Mobile Broadband Wireless Access Systems-Amendment for Physical and Medium Access Control Layers for Combined Fixed and Mobile Operation in Licensed Bands*, IEEE Std. 802.16e/D8-2005, May 20, 2005.
- [8] *IEEE Standard for Local and Metropolitan Area Networks Part 16: Air Interface for Fixed and Mobile Broadband Wireless Access Systems*, IEEE Std. 802.16-2009, 2009.
- [9] *WiMAX System Evaluation Methodology V2.1*, WiMAX Forum, Clackamas, OR, USA, Jul. 2008, p. 230. [Online]. Available: <http://www.cse.wustl.edu/~jain/wimax/wimaxsim.htm>
- [10] "General Packet Radio Service (GPRS) enhancements for Evolved Universal Terrestrial Radio Access Network (E-UTRAN) access (Release 8)," Sophia-Antipolis, France, 3GPP TS 23.401, 2009.
- [11] "Requirements for further advancements for EUTRA (LTE-Advanced)," Sophia-Antipolis, France, 3GPP TR 36.913 v8.0.0, Jun. 2008.
- [12] "Architecture enhancements for non-3GPP accesses (Release 8)," Sophia-Antipolis, France, 3GPP TS 23.402, Nov. 2008.
- [13] "Evolved Universal Terrestrial Radio Access (E-UTRA); Further advancements for E-UTRA physical layer aspects," Sophia-Antipolis, France, 3GPP TR 36.814 v1.0.0, Feb. 2009.
- [14] "Self-optimizing networks: The benefits of SON in LTE," Bellevue, WA, USA, White paper, Jul. 2011.
- [15] *Draft Supplement to Part 11: Wireless Medium Access Control (MAC) and Physical Layer (PHY) Specifications: Medium Access Control (MAC) Enhancements for Quality of Service (QoS)*, IEEE Std. 802.11e/D3.3.2, Nov. 2002, IEEE 802.11 WG, draft supp. to IEEE Std. 802.11, 1999 edition.
- [16] *Wireless LAN Medium Access Control (MAC) and Physical Layer (PHY) Specifications*, IEEE Std. 802.11, 1999.
- [17] *Wireless LAN Medium Access Control (MAC) and Physical Layer (PHY) Specifications: Medium Access Control (MAC) Enhancements for Quality of Service (QoS)*, IEEE 802.11e/D13.0, Part 11, Jan. 2005, draft supp. to IEEE 802.11 std.
- [18] F. Effenberger, G. Kramer, and B. Hesse, "Passive optical networking update [PON Update]," *IEEE Commun. Mag.*, vol. 45, no. 3, pp. S6–S8, Mar. 2007.
- [19] R. Yadav, "Passive-optical-network-(PON-) based converged access network [Invited]," *IEEE/OSA J. Opt. Commun. Netw.*, vol. 4, no. 11, pp. B124–B130, Nov. 2012.
- [20] N. Ghazisaidi, M. Maier, and C. M. Assi, "Fiber-Wireless (FiWi) access networks: A survey," *IEEE Commun. Mag.*, vol. 47, no. 2, pp. 160–167, Feb. 2009.
- [21] N. Ghazisaidi and M. Maier, "Fiber-Wireless (FiWi) access networks: Challenges and opportunities," *IEEE Netw.*, vol. 25, no. 1, pp. 36–42, Jan./Feb. 2011.
- [22] M. Maier, M. Levesque, and L. Ivanescu, "NG-PONs 1&2 and beyond: The dawn of the uber-FiWi network," *IEEE Netw.*, vol. 26, no. 2, pp. 15–21, Mar./Apr. 2012.
- [23] R. Q. Shaddad, A. B. Mohammad, S. A. Al-Gailani, A. M. Al-hetar, and M. A. Elmagzoub, "A survey on access technologies for broadband optical and wireless networks," *J. Netw. Comput. Appl.*, vol. 41, pp. 459–472, May 2014.
- [24] H. T. Win and A.-S. K. Pathan, "On the issues and challenges of Fiber-Wireless (Fi-Wi) networks," *J. Eng.*, vol. 2013, pp. 645745-1–645745-1, 2013.
- [25] M. P. McGarry and M. Reisslein, "Investigation of the DBA algorithm design space for EPONs," *J. Lightw. Technol.*, vol. 30, no. 14, pp. 2271–2280, Jul. 2012.
- [26] F. Effenberger *et al.*, "An introduction to PON technologies [Topics in Optical Communications]," *IEEE Commun. Mag.*, vol. 45, no. 3, pp. S17–S25, Mar. 2007.
- [27] F. Auzada, M. Scheutzow, M. Reisslein, N. Ghazisaidi, and M. Maier, "Capacity and delay analysis of Next-Generation Passive Optical Networks (NG-PONs)," *IEEE Trans. Commun.*, vol. 59, no. 5, pp. 1378–1388, May 2011.
- [28] J.-I. Kani *et al.*, "Next-generation PON—Part I: Technology roadmap and general requirements," *IEEE Commun. Mag.*, vol. 47, no. 11, pp. 43–49, Nov. 2009.
- [29] IEEE 802.3ah Task Force Home Page. [Online]. Available: <http://www.ieee802.org/3/efm>
- [30] G. Kramer and G. Pesavento, "Ethernet Passive Optical Network (EPON): Building a next-generation optical access network," *IEEE Commun. Mag.*, vol. 40, no. 2, pp. 66–73, Feb. 2002.
- [31] IEEE802.3av 10G-EPON Task Force. [Online]. Available: <http://www.ieee802.org/3/av/index.html>
- [32] J. Zhong and H. T. Mouftah, "Media access control for Ethernet passive optical networks: An overview," *IEEE Commun. Mag.*, vol. 43, no. 2, pp. 145–150, Feb. 2005.
- [33] *Gigabit-Capable Passive Optical Networks (G-PON): General Characteristics*, ITU-T G.984.1, SG 15, Mar. 2003.
- [34] *Gigabit-Capable Passive Optical Networks (G-PON): Physical Media Dependent (PMD) Layer Specification*, ITU-T G.984.2 SG 15, Mar. 2003.
- [35] *Gigabit-Capable Passive Optical Networks (G-PON): Transmission Convergence Layer Specification*, ITU-T G.984.3, SG 15, Jul. 2005.
- [36] *Gigabit-Capable Passive Optical Networks (G-PON): ONT Management and Control Interface Specification*, ITU-T G.984.4 SG 15, Jun. 2005.
- [37] *10-Gigabit-Capable Passive Optical Network (XG-PON) Systems: Definitions, Abbreviations, Acronyms*, ITU-T G.987, 2009.
- [38] *10-Gigabit-Capable Passive Optical Network (XG-PON): General Requirements*, ITU-T G.987.1, 2009.
- [39] *10-Gigabit-Capable Passive Optical Networks (XG-PON): Physical Media Dependent (PMD) Layer Specification*, ITU-T G.987.2, 2009.
- [40] *10-Gigabit-Capable Passive Optical Network (XG-PON) Systems: Transmission Convergence Layer Specification*, ITU-T G.987.3.
- [41] N. Cvijetic, "OFDM for next-generation optical access networks," *J. Lightw. Technol.*, vol. 30, no. 4, pp. 384–398, Feb. 2012.
- [42] W. Lim *et al.*, "Modeling of LTE back-hauling through OFDMA-PONs," in *Proc. 17th Int. Conf. ONDM*, Apr. 16–19, 2013, pp. 240–245.
- [43] C. So-In, R. Jain, and A.-K. Tamimi, "Scheduling in IEEE 802.16e mobile WiMAX networks: Key issues and a survey," *IEEE J. Sel. Areas Commun.*, vol. 27, no. 2, pp. 156–171, Feb. 2009.
- [44] *Overview of 3GPP Release 10 V0.1.5*, 3rd Generation Partnership Project, Sophia-Antipolis, France, Jun. 2012.
- [45] *Overview of 3GPP Release 8 V0.2.1*, 3rd Generation Partnership Project, Sophia-Antipolis, France, Sep. 2010.
- [46] M. Alasti, B. Neekzad, J. Hui, and R. Vannithamby, "Quality of service in WiMAX and LTE networks [Topics in Wireless Communications]," *IEEE Commun. Mag.*, vol. 48, no. 5, pp. 104–111, May 2010.
- [47] S. Mangold, S. Choi, G. R. Hiertz, O. Klein, and B. Walke, "Analysis of IEEE 802.11e for QoS support in wireless LANs," *IEEE Wireless Commun.*, vol. 10, no. 6, pp. 40–50, Dec. 2003.
- [48] Z. Jia, J. Yu, G. Ellinas, and G.-K. Chang, "Key enabling technologies for optical-wireless networks: Optical millimeter-wave generation, wavelength reuse, and architecture," *J. Lightw. Technol.*, vol. 25, no. 11, pp. 3452–3471, Nov. 2007.
- [49] J. Perez, M. Morant, R. Llorente, and J. Marti, "Joint distribution of polarization-multiplexed UWB and WiMAX radio in PON," *J. Lightw. Technol.*, vol. 27, no. 12, pp. 1912–1919, Jun. 2009.
- [50] J. Perez and R. Llorente, "Hybrid UWB and WiMAX radio-over-multi-mode fibre for in-building optical networks," *J. Opt.*, vol. 16, no. 1, p. 015401, Jan. 2014.
- [51] S. Sarkar, S. Dixit, and B. Mukherjee, "Hybrid wireless-optical broadband-access network (WOBAN): A review of relevant challenges," *J. Lightw. Technol.*, vol. 25, no. 11, pp. 3329–3340, Nov. 2007.
- [52] W. Shaw *et al.*, "Hybrid architecture and integrated routing in a scalable optical-wireless access network," *J. Lightw. Technol.*, vol. 25, no. 11, pp. 3443–3451, Nov. 2007.
- [53] S. Sarkar, B. Mukherjee, and S. Dixit, "Optimum placement of multiple Optical Network Units (ONUs) in optical-wireless hybrid access networks," in *Proc. Opt. Fiber Commun. Conf.*, Anaheim, CA, USA, Mar. 2006, pp. 1–3.
- [54] I. Filippini and M. Cesana, "Topology optimization for hybrid optical/wireless access networks," *Ad Hoc Netw.*, vol. 8, no. 6, pp. 614–625, Aug. 2010.

- [55] G. Shen, R. S. Tucker, and C.-J. Chae, "Fixed mobile convergence architectures for broadband access: Integration of EPON and WiMAX," *IEEE Commun. Mag.*, vol. 45, no. 8, pp. 44–50, Aug. 2007.
- [56] G. Shen and R. Tucker, "Fixed Mobile Convergence (FMC) Architecture for broadband access: Integration of EPON and WiMAX (invited)," in *Proc. SPIE Netw. Architectures, Manage., Appl.*, Nov. 2007, vol. 6784, pp. 678403-1–678403-13.
- [57] I.-S. Hwang, J.-Y. Lee, C.-W. Huang, and Z.-D. Shyu, "Advanced dynamic bandwidth allocation and scheduling scheme for the integrated architecture of EPON and WiMAX," in *Proc. 10th Int. Conf. MDM—Syst., Serv. Middleware*, May 18–20, 2009, pp. 655–660.
- [58] G. Ming, L. Bin, and P.-H. Ho, "BU association and resource allocation in integrated PON-WiMAX under inter-cell cooperative transmission," in *Proc. 5th IEEE ISWPC*, May 5–7, 2010, pp. 606–611.
- [59] M. Mirahmadi and A. Shami, "Traffic-prediction-assisted dynamic bandwidth assignment for hybrid wireless optical networks," in *Proc. 7th IWCMC*, Jul. 4–8, 2011, pp. 2103–2108.
- [60] A. Ahmed and A. Shami, "A new bandwidth allocation algorithm for EPON-WiMAX hybrid access networks," in *Proc. IEEE GLOBECOM*, Dec. 6–10, 2010, pp. 1–6.
- [61] B. Jung, J.-Y. Choi, Y.-T. Han, M.-G. Kim, and M. Kang, "Centralized scheduling mechanism for enhanced end-to-end delay and QoS support in integrated architecture of EPON and WiMAX," *J. Lightw. Technol.*, vol. 28, no. 16, pp. 2277–2288, Aug. 15, 2010.
- [62] A. Nirmalathas, D. Novak, C. Lim, and R. B. Waterhouse, "Wavelength reuse in the WDM optical interface of a millimeter-wave fiber-wireless antenna base station," *IEEE Trans. Microw. Theory Tech.*, vol. 49, no. 10, pp. 2006–2012, Oct. 2001.
- [63] K. Yang, S. Ou, K. Guild, and H.-H. Chen, "Convergence of ethernet PON and IEEE 802.16 broadband access networks and its QoS-aware dynamic bandwidth allocation scheme," *IEEE J. Sel. Areas Commun.*, vol. 27, no. 2, pp. 101–116, Feb. 2009.
- [64] S. Ou, K. Yang, M. P. Farrera, C. Okonkwo, and K. M. Guild, "A control bridge to automate the convergence of passive optical networks and IEEE 802.16 (WiMAX) wireless networks," in *Proc. 5th Int. Conf. BROADNETS Commun.*, Sep. 8–11, 2008, pp. 514–521.
- [65] T. Tang, G. Shou, Y. Hu, and Z. Guo, "Performance analysis of bandwidth allocation of convergence of WiMAX and EPON," in *Proc. Int. Conf. NSWCTC*, Apr. 25–26, 2009, vol. 1, pp. 662–665.
- [66] M. Jarschel, T. Zinner, T. Hossfeld, P. Tran-Gia, and W. Kellerer, "Interfaces, attributes, and use cases: A compass for SDN," *IEEE Commun. Mag.*, vol. 52, no. 6, pp. 210–217, Jun. 2014.
- [67] M. Giuntini, A. Valenti, F. Matera, and S. Di Bartolo, "Quality of service management in hybrid optical-LTE access networks," in *Proc. FutureNetw Mobile Summit*, Jun. 15–17, 2011, pp. 1–7.
- [68] M. A. Ali, G. Ellinas, H. Erkan, A. Hadjiantonis, and R. Dorsinville, "On the vision of complete fixed-mobile convergence," *J. Lightw. Technol.*, vol. 28, no. 16, pp. 2343–2357, Aug. 15, 2010.
- [69] N. Moradpoor, G. Parr, S. McClean, B. Scotney, and G. Owusu, "Hybrid optical and wireless technology integrations for next generation broadband access networks," in *Proc. IFIP/IEEE Int. Symp. IM Netw.*, May 23–27, 2011, pp. 1013–1020.
- [70] M. P. McGarry, M. Reisslein, and M. Maier, "WDM Ethernet passive optical networks," *IEEE Commun. Mag.*, vol. 44, no. 2, pp. 15–22, Feb. 2006.
- [71] Y. Li *et al.*, "Integrated Fiber-Wireless (FiWi) access networks supporting inter-ONU communications," *J. Lightw. Technol.*, vol. 28, no. 5, pp. 714–724, Mar. 2010.
- [72] M. Levesque, D.-Q. Xu, G. Joos, and M. Maier, "Co-Simulation of PEV coordination schemes over a FiWi Smart Grid communications infrastructure," in *Proc. 38th IEEE IECON/IECON*, Oct. 25–28, 2012, pp. 2901–2906.
- [73] M. Maier, "Fiber-Wireless Sensor Networks (Fi-WSNs) for smart grids," in *Proc. 13th ICTON*, Jun. 26–30, 2011, pp. 1–4.
- [74] F. Auzada, M. Levesque, M. Maier, and M. Reisslein, "FiWi access networks based on next-generation PON and gigabit-class WLAN technologies: A capacity and delay analysis," *IEEE/ACM Trans. Netw.*, vol. 22, no. 4, pp. 1176–1189, Aug. 2014.
- [75] M. Maier, N. Ghazisaidi, and M. Reisslein, "The audacity of Fiber-Wireless (FiWi) networks (Invited Paper)," in *Proc. ICST ACCESSNETS*, Las Vegas, NV, USA, Oct. 2008, pp. 1–10.
- [76] M. P. McGarry, M. Reisslein, and M. Maier, "Ethernet passive optical network architectures and dynamic bandwidth allocation algorithms," *IEEE Commun. Surveys Tuts.*, vol. 10, no. 3, pp. 46–60, 2008.
- [77] I.-S. Hwang and J.-Y. Lee, "Performance study of homogeneous uplink scheduling in hybrid ONU-BS architecture," in *Proc. Int. MultiConf. Eng. Comput. Scientists*, Hong Kong, Mar. 16–18, 2011, vol. 1, pp. 1–6.
- [78] M. Mirahmadi and A. Shami, "Traffic-prediction-assisted dynamic bandwidth assignment for hybrid optical wireless networks," *Comput. Netw.*, vol. 56, no. 1, pp. 244–259, Jan. 2012.
- [79] W. Lim, M. Milosavljevic, P. Kourtessis, and M. John, "QoS mapping for LTE backhauling over OFDMA-PONs," in *Proc. 14th ICTON*, Jul. 2–5, 2012, pp. 1–4.
- [80] A. R. Dhaini, P.-H. Ho, and X. Jiang, "WiMAX-VPON: A Framework of Layer-2 VPNs for next-generation access networks," *IEEE/OSA J. Opt. Commun. Netw.*, vol. 2, no. 7, pp. 400–414, Jul. 2010.
- [81] A. Ahmed and A. Shami, "RPR-EPON-WiMAX hybrid network: A solution for access and metro networks," *IEEE/OSA J. Opt. Commun. Netw.*, vol. 4, no. 3, pp. 173–188, Mar. 2012.
- [82] A. R. Dhaini, P.-H. Ho, and X. Jiang, "QoS control for guaranteed service bundles over Fiber-Wireless (FiWi) broadband access networks," *J. Lightw. Technol.*, vol. 29, no. 10, pp. 1500–1513, May 2011.
- [83] C. Ranaweera, E. Wong, C. Lim, and A. Nirmalathas, "Quality of service assurance in EPON-WiMAX converged network," in *Proc. Int. Top. Meet. MWP/APMP*, Oct. 18–21, 2011, pp. 369–372.
- [84] A. R. Dhaini and P.-H. Ho, "MC-FiWiBAN: An emergency-aware mission-critical fiber-wireless broadband access network," *IEEE Commun. Mag.*, vol. 49, no. 1, pp. 134–142, Jan. 2011.
- [85] N. Moradpoor, G. Parr, S. McClean, and B. Scotney, "IIDWBA algorithm for integrated hybrid PON with wireless technologies for next generation broadband access networks," *Opt. Switching Netw.*, vol. 10, no. 4, pp. 439–457, Nov. 2013.
- [86] C. M. Assi, Y. Ye, S. Dixit, and M. A. Ali, "Dynamic bandwidth allocation for quality-of-service over Ethernet PONs," *IEEE J. Sel. Areas Commun.*, vol. 21, no. 9, pp. 1467–1477, Nov. 2003.
- [87] G. Kramer, B. Mukherjee, S. Dixit, Y. Ye, and R. Hirth, "Supporting differentiated classes of service in Ethernet passive optical networks," *IEEE/OSA J. Opt. Commun. Netw.*, vol. 1, no. 8, pp. 280–298, Aug. 2002.
- [88] A. R. Dhaini, C. M. Assi, M. Maier, and A. Shami, "Admission control in Ethernet Passive Optical Networks (EPONs)," in *Proc. IEEE ICC*, Jun. 24–28, 2007, pp. 2162–2167.
- [89] A. R. Dhaini, C. M. Assi, M. Maier, and A. Shami, "Per-stream QoS and admission control in Ethernet Passive Optical Networks (EPONs)," *J. Lightw. Technol.*, vol. 25, no. 7, pp. 1659–1669, Jul. 2007.
- [90] Y. Yan, H. Yu, H. Wessing, and L. Dittmann, "Integrated resource management for Hybrid Optical Wireless (HOW) networks," in *Proc. 4th Int. Conf. ChinaCOM Netw.*, Aug. 26–28, 2009, pp. 1–5.
- [91] P. G. Sarigiannidis, S. G. Petridou, G. I. Papadimitriou, and M. S. Obaidat, "IGFS: A new MAC protocol exploiting heterogeneous propagation delays in the dynamic bandwidth allocation on WDM-EPON," *IEEE Syst. J.*, vol. 4, no. 1, pp. 49–56, Mar. 2010.
- [92] M. P. McGarry, M. Reisslein, F. Auzada, and M. Scheutzw, "Shortest Propagation Delay (SPD) first scheduling for EPONs with heterogeneous propagation delays," *IEEE J. Sel. Areas Commun.*, vol. 28, no. 6, pp. 849–862, Aug. 2010.
- [93] K. Iniewski, Ed., *Convergence of mobile and stationary next-generation networks*. Hoboken, NJ, USA: Wiley, 2011.
- [94] A. Dhaini, C. M. Assi, M. Maier, and A. Shami, "Dynamic wavelength and bandwidth allocation in hybrid TDM/WDM EPON networks," *J. Lightw. Technol.*, vol. 25, no. 1, pp. 277–286, Jan. 2007.
- [95] X. Bai, A. Shami, and C. Assi, "On the fairness of dynamic bandwidth allocation schemes in ethernet passive optical networks," *Comput. Commun.*, vol. 29, no. 11, pp. 2123–2135, Jul. 2006.
- [96] L. Jiang, M.-L. Fu, and Z.-C. Le, "Hierarchical QoS-aware dynamic bandwidth allocation algorithm for wireless optical broadband access network," in *Proc. ICECC*, Sep. 9–11, 2011, pp. 4329–4332.
- [97] S. Ou, K. Yang, and H.-H. Chen, "Integrated dynamic bandwidth allocation in converged passive optical networks and IEEE 802.16 networks," *IEEE Syst. J.*, vol. 4, no. 4, pp. 467–476, Dec. 2010.
- [98] OMNeT++ simulator. [Online]. Available: <http://www.omnetpp.org/>
- [99] Z. Md Fadlullah *et al.*, "Cooperative QoS control scheme based on scheduling information in FiWi access network," *IEEE Trans. Emerg. Topics in Comp.*, vol. 1, no. 2, pp. 375–383, Dec. 2013.
- [100] Opnet simulator. [Online]. Available: www.opnet.com
- [101] D. Qian, J. Hu, P. Ji, T. Wang, and M. Cvjetich, "10-Gb/s OFDMA-PON for delivery of heterogeneous services," presented at the Optical Fiber Communication Conference, San Diego, CA, USA, 2008, Paper OWH4.
- [102] L. Shiliang, W. Jianping, Q. Chunming, and X. Yinlong, "Mitigating packet reordering in FiWi networks," *IEEE/OSA J. Opt. Commun. Netw.*, vol. 3, no. 2, pp. 134–144, Feb. 2011.
- [103] G. Kramer, B. Mukherjee, and G. Pesavento, "IPACT a dynamic protocol for an Ethernet PON (EPON)," *IEEE Commun. Mag.*, vol. 40, no. 2, pp. 74–80, Feb. 2002.

- [104] N. Ghazisaidi, M. Maier, and M. Reisslein, "VMP: A MAC protocol for EPON-based video-dominated FiWi access networks," *IEEE Trans. Broadcast.*, vol. 58, no. 3, pp. 440–453, Sep. 2012.
- [105] H.-J. Byun, J.-M. Nho, and J.-T. Lim, "Dynamic bandwidth allocation algorithm in ethernet passive optical networks," *Electron. Lett.*, vol. 39, no. 13, pp. 1001–1002, Jun. 2003.
- [106] Y. Luo and N. Ansari, "Bandwidth allocation for multiservice access on EPONs," *IEEE Commun. Mag.*, vol. 43, no. 2, pp. S16–S21, Feb. 2005.
- [107] Y. Luo and N. Ansari, "Limited sharing with traffic prediction for dynamic bandwidth allocation and QoS provisioning over ethernet passive optical networks," *IEEE/OSA J. Opt. Commun. Netw.*, vol. 4, no. 9, pp. 561–572, Sep. 2005.
- [108] S. Haykin, *Neural Networks: A Comprehensive Foundation*, 2nd ed. Upper Saddle River, NJ, USA: Prentice Hall, 1999.
- [109] S. A. M. Ostring and H. Sirisena, "The influence of long-range dependence on traffic prediction," in *Proc. IEEE ICC*, 2001, vol. 4, pp. 1000–1005.
- [110] D. Bojic *et al.*, "Advanced wireless and optical technologies for small-cell mobile backhaul with dynamic software-defined management," *IEEE Commun. Mag.*, vol. 51, no. 9, pp. 86–93, Sep. 2013.
- [111] T. Nakamura *et al.*, "Trends in small cell enhancements in LTE advanced," *IEEE Commun. Mag.*, vol. 51, no. 2, pp. 98–105, Feb. 2013.
- [112] D. Bladsjo, M. Hogan, and S. Ruffini, "Synchronization aspects in LTE small cells," *IEEE Commun. Mag.*, vol. 51, no. 9, pp. 70–77, Sep. 2013.
- [113] R. Giddings, "Real-time digital signal processing for optical OFDM-based future optical access networks," *J. Lightw. Technol.*, vol. 32, no. 4, pp. 553–570, Feb. 2014.
- [114] N. Cvijetic *et al.*, "Novel optical access and digital processing architectures for future mobile backhaul," *J. Lightw. Technol.*, vol. 31, no. 4, pp. 621–627, Feb. 2013.
- [115] D. Linglong, Z. Xu, and Z. Wang, "Flexible multi-block OFDM transmission for high-speed fiber-wireless networks," *IEEE J. Sel. Areas Commun.*, vol. 31, no. 12, pp. 788–796, Dec. 2013.
- [116] S. Aleksic *et al.*, "Energy efficiency of femtocell deployment in combined wireless/optical access networks," *Comput. Netw.*, vol. 57, no. 5, pp. 1217–1233, Apr. 2013.
- [117] H. ElSawy, E. Hossain, and D. I. Kim, "HetNets with cognitive small cells: User offloading and distributed channel access techniques," *IEEE Commun. Mag.*, vol. 51, no. 6, pp. 28–36, Jun. 2013.
- [118] C. Ranaweera *et al.*, "Design and optimization of fiber optic small-cell backhaul based on an existing fiber-to-the-node residential access network," *IEEE Commun. Mag.*, vol. 51, no. 9, pp. 62–69, Sep. 2013.
- [119] N. M. M. K. Chowdhury and R. Boutaba, "A survey of network virtualization," *Comput. Netw.*, vol. 54, no. 5, pp. 862–876, Apr. 2010.
- [120] N. M. M. K. Chowdhury and R. Boutaba, "Network virtualization: State of the art and research challenges," *IEEE Commun. Mag.*, vol. 47, no. 7, pp. 20–26, Jul. 2009.
- [121] S. He, G. Shou, Y. Hu, and Z. Guo, "Performance of multipath in Fiber-Wireless (FiWi) access network with network virtualization," in *Proc. IEEE MILCOM Conf.*, Nov. 18–20, 2013, pp. 928–932.
- [122] Q. Dai, G. Shou, Y. Hu, and Z. Guo, "A general model for hybrid fiber-wireless (FiWi) access network virtualization," in *Proc. IEEE ICC Workshops*, Jun. 9–13, 2013, pp. 858–862.
- [123] A. Tzanakaki *et al.*, "Virtualization of heterogeneous wireless-optical network and IT infrastructures in support of cloud and mobile cloud services," *IEEE Commun. Mag.*, vol. 51, no. 8, pp. 155–161, Aug. 2013.
- [124] N. Ghazisaidi, M. Scheutzw, and M. Maier, "Survivability analysis of next-generation passive optical networks and fiber-wireless access networks," *IEEE Trans. Rel.*, vol. 60, no. 2, pp. 479–492, Jun. 2011.
- [125] M. Maier, "Reliable fiber-wireless access networks: Less an end than a means to an end," in *Proc. 9th Int. Conf. DRCN*, Mar. 4–7, 2013, pp. 119–130.
- [126] L. Guo, Y. Liu, F. Wang, W. Hou, and B. Gong, "Cluster-based protection for survivable fiber-wireless access networks," *IEEE/OSA J. Opt. Commun. Netw.*, vol. 5, no. 11, pp. 1178–1194, Nov. 2013.
- [127] Y. Liu, L. Guo, R. Ma, and W. Hou, "Auxiliary graph based protection for survivable Fiber-Wireless (FiWi) access network considering different levels of failures," *Opt. Fiber Technol.*, vol. 18, no. 6, pp. 430–439, Dec. 2012.
- [128] S. Thota, P. Bhaumik, P. Chowdhury, B. Mukherjee, and S. Sarkar, "Exploiting wireless connectivity for robustness in WOBAN," *IEEE Netw.*, vol. 27, no. 4, pp. 72–79, Jul./Aug. 2013.
- [129] U. R. Bhatt, T. Sarsodia, and R. Upadhyay, "Survivability of a integrated fiber-wireless (FiWi) access networks," in *Proc. ICICT*, Feb. 7–8, 2014, pp. 238–243.
- [130] Y. Yu, Y. Liu, Y. Zhou, and P. Han, "Planning of survivable cloud-integrated wireless-optical broadband access network against distribution fiber failure," *Opt. Switching Netw.*, vol. 14, pt. 3, pp. 217–225, Aug. 2014.
- [131] Y. Liu, Q. Song, B. Li, and R. Ma, "Load balanced Optical Network Unit (ONU) placement in cost-efficient Fiber-Wireless (FiWi) access network," *Optik*, vol. 124, no. 20, pp. 4594–4601, Oct. 2013.
- [132] Y. Liu *et al.*, "Green survivability in Fiber-Wireless (FiWi) broadband access network," *Opt. Fiber Technol.*, vol. 18, no. 2, pp. 68–80, Mar. 2012.
- [133] G. Zhang, M. De Leenheer, A. Morea, and B. Mukherjee, "A survey on OFDM-based elastic core optical networking," *IEEE Commun. Surveys Tuts.*, vol. 15, no. 1, pp. 65–87, 2013.
- [134] P. Layec, A. Morea, F. Vacondio, O. Rival, and J.-C. Antona, "Elastic optical networks: The global evolution to software configurable optical networks," *Bell Labs Tech. J.*, vol. 18, no. 3, pp. 133–151, Dec. 2013.
- [135] M. Jinno *et al.*, "Elastic and adaptive optical networks: Possible adoption scenarios and future standardization aspects," *IEEE Commun. Mag.*, vol. 49, no. 10, pp. 164–172, Oct. 2011.
- [136] W. Ji and Z. Kang, "Design of WDM RoF PON based on OFDM and optical heterodyne," *IEEE/OSA J. Opt. Commun. Netw.*, vol. 5, no. 6, pp. 652–657, Jun. 2013.
- [137] T. Tsagklas and F. N. Pavlidou, "A survey on radio-and-fiber FiWi network architectures," *J. Sel. Areas Telecommun.*, pp. 18–24, Mar. 2011, Cyber Journals, March Edition, 2011.
- [138] S. Aissa and M. Maier, "Towards seamless Fiber-Wireless (FiWi) access networks: Convergence and challenges," in *Proc. ICTON MW Conf.*, Dec. 6–8, 2007, pp. 1–6.
- [139] M. Maier and N. Ghazisaidi, "QoS provisioning techniques for future Fiber-Wireless (FiWi) access networks," *Future Internet*, vol. 2, no. 2, pp. 126–155, Jun. 2010.
- [140] N. Ghazisaidi, C. Lange, A. Gladisch, and M. Maier, "Concepts, potentials and limitations of fiber-copper and Fiber-Wireless (FiWi) networks," presented at the Access Networks and In-house Communications, Karlsruhe, Germany, 2010, Paper AWC3.
- [141] J. Coimbra, G. Schütz, and N. Correia, "A game-based algorithm for fair bandwidth allocation in Fibre-Wireless access networks," *Opt. Switching Netw.*, vol. 10, no. 2, pp. 149–162, Apr. 2013.
- [142] C. Lange and A. Gladisch, "On the energy consumption of FTTH access networks," presented at the Optical Fiber Communication Conference, San Diego, CA, USA, Mar. 2009, Paper JThA79.
- [143] X. Liu, N. Ghazisaidi, L. Ivanescu, R. Kang, and M. Maier, "On the tradeoff between energy saving and QoS support for video delivery in EEE-Based FiWi networks using real-world traffic traces," *J. Lightw. Technol.*, vol. 29, no. 18, pp. 2670–2676, Sep. 2011.
- [144] J. Coimbra, G. Schütz, and N. Correia, "Energy efficient routing algorithm for fiber-wireless access networks: A network formation game approach," *Comput. Netw.*, vol. 60, no. 26, pp. 201–216, Feb. 2014.
- [145] H. Chowdhury, I. Ashraf, and M. Katz, "Energy-efficient connectivity in hybrid radio-optical wireless systems," in *Proc. 10th ISWCS*, Aug. 27–30, 2013, pp. 1–5.
- [146] K. Togashi *et al.*, "On the effect of cooperation between power saving mechanisms in WLANs and PONs," in *Proc. IEEE ICC*, Jun. 9–13, 2013, pp. 6225–6229.
- [147] Z. Md Fadlullah *et al.*, "Smart FiWi networks: Challenges and solutions for QoS and green communications," *IEEE Intell. Syst.*, vol. 28, no. 2, pp. 86–91, Mar./Apr. 2013.
- [148] X. Gong, W. Hou, L. Guo, and L. Zhang, "Dynamic energy-saving algorithm in green hybrid wireless-optical broadband access network," *Optik*, vol. 124, no. 14, pp. 1874–1881, Jul. 2013.
- [149] K. Togashi *et al.*, "Cross layer analysis on ONU energy consumption in smart FiWi networks," *IEEE Wireless Commun. Lett.*, vol. 2, no. 6, pp. 695–698, Dec. 2013.
- [150] Y. Liu, L. Guo, and J. Yang, "Energy-efficient topology reconfiguration in green Fiber-Wireless (FiWi) access network," in *Proc. WOCC*, May 16–18, 2013, pp. 555–559.
- [151] L. G. Kazovsky *et al.*, "How to design an energy efficient fiber-wireless network," in *Proc. OFC/NFOEC*, Mar. 17–21, 2013, pp. 1–3.
- [152] B. Kantarci, N. Naas, and H. T. Mouftah, "Energy-efficient DBA and QoS in FiWi networks constrained to metro-access convergence," in *Proc. 14th ICTON*, Jul. 2–5, 2012, pp. 1–4.
- [153] N. Zaker, B. Kantarci, M. Erol-Kantarci, and H. T. Mouftah, "Quality-of-service-aware fiber wireless sensor network gateway design for the smart grid," in *Proc. IEEE ICC Workshops*, Jun. 9–13, 2013, pp. 863–867.

- [154] *IEEE Draft Standard for Local and Metropolitan Area Networks—Part 15.4: Wireless Medium Access Control (MAC) and Physical Layer (PHY) Specifications for Low Rate Wireless Personal Area Networks (WPANs) Amendment-Physical Layer (PHY) Specifications for Low Energy, Critical Infrastructure Monitoring Networks (LECM)*, IEEE Std. P802.15.4k/D3, Nov. 2012, pp. 1–133, Jan. 10, 2013.
- [155] A. Sarigiannidis, P. Nicopolitidis, G. Papadimitriou, P. Sarigiannidis, and M. Louta, “Using learning automata for adaptively adjusting the downlink-to-uplink ratio in IEEE 802.16e wireless networks,” in *Proc. IEEE ISCC*, Jun. 28–Jul. 1, 2011, pp. 353–358.
- [156] P. G. Sarigiannidis, G. I. Papadimitriou, P. Nicopolitidis, M. S. Obaidat, and A. S. Pomportsis, “A novel adaptive mapping scheme for IEEE 802.16 mobile downlink framing,” in *Proc. IEEE GLOBECOM*, Dec. 6–10, 2010, pp. 1–5.



Antonios G. Sarigiannidis (S'13) received the B.S. and M.S. degrees in computer science from the Department of Informatics, Aristotle University, Thessaloniki, Greece, in 2007 and 2009, respectively. He is pursuing the Ph.D. degree in hybrid optical-wireless networks at the same university. His research interests include optical, wireless, and hybrid optical-wireless networks.



Maria Iloridou received the Diploma degree in electrical and computer engineering from the Faculty School of Aristotle University of Thessaloniki, Greece, in 2012. She is pursuing the Ph.D. degree in the same department. Her research interests include MAC protocol analysis and performance evaluation of broadband wireless and heterogeneous networks. She is a member of the Technical Chamber of Greece.



Petros Nicopolitidis (SM'12) received the B.S. and Ph.D. degrees in computer science from the Department of Informatics, Aristotle University of Thessaloniki, Greece, in 1998 and 2002, respectively. From 2004 to 2009, he was a Lecturer in the same Department, where he currently serves as an Assistant Professor. He has published more than 100 papers in international refereed journals and conferences. He is co-author of the book *Wireless Networks* (Wiley, 2003). His research interests are in the areas of wireless networks and mobile communications.

He serves as an Associate Editor for the *International Journal of Communication Systems* and the *Security and Communication Networks* journal, both published by Wiley.



Georgios Papadimitriou (M'89–SM'02) received the Diploma and Ph.D. degrees in computer engineering from the University of Patras, Greece, in 1989 and 1994, respectively. In 1997, he joined the faculty of the Department of Informatics, Aristotle University of Thessaloniki, Greece, where he is currently serving as Professor. His main research interests include optical networks and wireless networks. He is Associate Editor of four IEEE journals. He is co-author of three international books published by Wiley. He is author or coauthor of more than 100

journal and 100 conference papers.



Fotini-Niovi Pavlidou (SM'00) received the Diploma in mechanical/electrical engineering and the Ph.D. degree in telecommunications networks from the Aristotle University of Thessaloniki (AUTH), Greece. She is currently a Professor at the same Institution, engaged in lectures, laboratory courses, and research in mobile communications and telecommunications networks. Her research interests include traffic analysis and design (MAC protocols and routing techniques) of wireless (terrestrial, satellite, ad hoc, sensor) networks, performance evaluation, security and QoS studies and multimedia applications over Internet. She has published over 160 papers in scientific journals and conferences in these fields. She has served as Guest Editor for many special issues on networking topics, she served as Division Editor for the *Journal of Communications Networks*, as Editor for the IEEE TRANSACTIONS ON WIRELESS COMMUNICATIONS, the IEEE COMMUNICATIONS LETTERS and as Editor for the *Wireless Personal Communications* journal. She is permanently included on the technical program committees of many IEEE conferences. She has been involved in many European research and educational projects. She has served as a volunteer for many IEEE positions.



Panagiotis G. Sarigiannidis (S'05–M'07) received the B.Sc. and Ph.D. degrees in computer science from the Aristotle University of Thessaloniki, Thessaloniki, Greece, in 2001 and 2007, respectively. He is currently a Lecturer with the University of Western Macedonia, Kozani, Greece. His research interests include medium access protocols in optical networks, dynamic bandwidth allocation schemes in passive optical networks, scheduling policies in IEEE 802.16 wireless networks, wireless push systems design and optimization, quality of service provisioning in optical and wireless networks, traffic estimation and prediction via numerical analysis, and design of burst allocation for optical burst switching networks. He has published over 65 papers in international journals, conferences, and book chapters.



Malamati D. Louta (SM'14) received the M.Eng. and Ph.D. degrees in electrical and computer engineering in 1997 and 2000, respectively, and the M.B.A. degree in 2004 from the National Technical University of Athens. She is an Assistant Professor with the Department of Informatics and Telecommunications Engineering, University of Western Macedonia, Greece. She was a member of the staff of Public Power Corporation (1999–2005), Assistant Professor at the Department of Business Administration, T.E.I. of Western Macedonia (2005–2008), and Lecturer with the Department of Informatics and Telematics, Harokopio University of Athens (2008–2010). Her research interests include telecommunication networks and advanced services engineering. She is the author of over 60 peer-reviewed publications. She serves as an Associate Editor, technical program committee member, and Reviewer for a number of international conferences and journals. She is member of the ACM and the Technical Chamber of Greece.



Vasileios Vitsas received the B.Sc. degree in electrical engineering from University of Thessaloniki, Greece, in 1983, the M.Sc. degree in computer science from University of California, Santa Barbara, CA, USA, in 1986, and the Ph.D. degree in wireless communications from Bournemouth University, U.K., in 2002. His Ph.D. research was in the area of mathematical modeling and optimizing the performance of wireless local area networks. In 1988, he joined the Hellenic Telecommunications Organization where he worked in the field of X.25

packet switching networks. In 1994, he joined the Information Technology Department, Technological Educational Institution of Thessaloniki (TEI-Th), Greece, as a Lecturer in computer networks. In 2003, 2005, and 2009 he became an Assistant Professor, Associate Professor, and Professor, respectively, with the same department. In 2009, he became Director of the Computer Systems, Security and Networks Lab, Information Technology Department, TEI-Th. He has also served as Head of the Department and Head of the Division, Information Technology Department, TEI-Th.